



**OIL INDIA LIMITED**  
(A Government of India Enterprises)  
PO : Duliajan – 786602  
Assam (India)

TELEPHONE NO. (91-374) 2808757

FAX NO: (91-374) 2800533

Email: ankurjyoti\_sarmah@oilindia.in; erp\_mm@oilindia.in

**FORWARDING LETTER**

Tender No. : SDI1956P20 DT: 15.07.2019  
Tender Fee : NIL  
Bid Security : Applicable  
Bidding Type : SINGLE STAGE TWO BID SYSTEM  
Bid Closing on : 10.10.2019 (11.00 HRS IST)  
Bid Opening on : 10.10.2019 (14.00 HRS IST)  
Performance Security : Applicable  
Integrity Pact : Applicable

The complete bid documents and details for purchasing bid documents, participation in E-tenders are available on OIL's e-procurement portal <https://etender.srm.oilindia.in/irj/portal> as well as OIL's website [www.oil-india.com](http://www.oil-india.com).

**NOTE:** All addenda, Corrigenda, time extension etc. to the tenders will be hosted on above website and e-portal only. Bidders should regularly visit above website and e-portal to keep themselves updated.

**The items covered by this enquiry shall be used by Oil India Limited in the PEL/ML areas which are issued/renewed after 01/04/99 and hence concessional rate of GST @5% against Essentiality Certificate for invoice value 1 Lakh and above will be applicable as per Notification No. 3/2017- Integrated/ Central Tax (Rate) dated 28th June, 2017.**

**In the event of order, OIL will issue Essentiality Certificate (EC), where concessional rate of GST @5% will be applicable. Supplier shall affect dispatch only on receipt of this certificate from OIL, failing which all related liabilities shall be to Supplier's account.**

OIL invites Bids for **PROCUREMENT OF CREW CABINS (Qty– 23 NOS.)** through its e-Procurement site under **SINGLE STAGE TWO BID SYSTEM**. The bidding documents and other terms and conditions are available at Booklet No. MM/LOCAL/E-01/2005 for E-Procurement of Indigenous Tenders. The prescribed Bid Forms for submission of bids are available in the Technical RFx -> External Area -> Tender Documents

The general details of tender can be viewed by opening the RFx [ Tender] under RFx and Auctions. The details of items tendered can be found in the Item Data and details uploaded under Technical RFx.

**This Tender has been floated for participation of Indigenous bidders only. Hence, only Indigenous bidders are eligible to participate against this tender.**

**Consortiums/Joint venture entities are not eligible to participate against this tender.**

**The tender will be governed by:**

- a) For technical support on various matters viz. Online registration of vendors, Resetting of Passwords, submission of online bids etc, vendors should contact OIL's ERP MM Deptt at following: Tel Nos. = **0374-2807178/ 2807171/ 2807192/2804903.** Email id = [erp\\_mm@oilindia.in](mailto:erp_mm@oilindia.in); [esupport@oilindia.in](mailto:esupport@oilindia.in)

- b) OIL's office timings are as below:

|                     | Time (in IST)                              |
|---------------------|--|
| Monday – Friday     | 07.00 AM to 11.00 AM; 12.30 PM to 03.30 PM |
| Saturday            | 07.00 AM to 11.00 AM                       |
| Sunday and Holidays | Closed                                     |

Vendors should contact OIL officials at above timings only.

**OIL Bank Details :**

|   | Bank Details of Beneficiary |  |
|---|-----------------------------|--|
| a | Bank Name                   | STATE BANK OF INDIA  |
| b | Branch Name                 | Duliajan   |
| c | Branch Address              | Duliajan, Dist-Dibrugarh                                     |
| d | Banker Account No.          | 10494832599  |
| e | Type of Account             | Current Account  |
| f | IFSC Code                   | SBIN0002053  |
| g | MICR Code                   | 786002302  |
| h | SWIFT Code                  | SBININBB479  |
| i | Contact No.                 | 9435554859   |
| j | Contact Person Name         | Mr. K.L.K.Banik, AGM   |
| k | Fax No.                     | 0374-2802729   |
| l | Email Id                    | <a href="mailto:sbi.02053@sbi.co.in">sbi.02053@sbi.co.in</a> |

- c) "General Terms & Conditions" for e-Procurement as per Booklet No. MM/LOCAL/E-01/2005 for E-Procurement of Indigenous Tenders.
- d) Technical specifications and Quantity as per **Annexure – IA**.
- e) The prescribed Bid Forms for submission of bids are available in the Technical RFx -> External Area -> Tender Documents.
- f) Amendments to the NIT after its issue will be published on OIL's website only. Revision, clarification, addendum, corrigendum, time extension etc. to the tender will be hosted on OIL website only. No separate notification shall be issued in the press. Prospective bidders are requested to visit website regularly to keep themselves updated.

- g) Any sum of money due and payable to the contractor (including Security Deposit refundable to them) under this or any other contract may be appropriated by Oil India Limited and set-off against any claim of Oil India Limited (or such other person or persons contracting through Oil India Limited) for payment of sum of money arising out of this contract or under any other contract made by the contractor with Oil India Limited (or such other person or persons contracting through Oil India Limited).
- h) Bidder are advised to fill up the Technical bid check list (**Annexure EEE**) and Response sheet (**Annexure FFF**) given in MS excel format in Technical RFx -> External Area - > Tender Documents. The above filled up document to be uploaded in the **Technical Attachment**. For details please refer “Vendor User Manual” / “NEW INSTRUCTIONS”

---

### **Special Notes:**

#### **1.0**

- a) Bidders who do not have E-tender Login ID and Password should complete their online registration **at least seven (7) days prior to the scheduled bid closing date** and time of the tender. For online registration, Bidder may visit the OIL’s E-tender site <https://etender.srm.oilindia.in/irj/portal>
- b) Necessary Login ID & Password will be issued by OIL only after submitting the complete online registration by the Bidder. In the event of late registration/incomplete registration by Bidder, OIL INDIA LIMITED shall not be responsible for late allotment of User ID & Password and request for bid closing date extension on that plea shall not be entertained by Company.
- c) **MSE Units** (Manufacturers/Service Providers only and not their dealers/distributors) who are already registered with District Industry Centers or Khadi & Village Industries Commission or Khadi & Village Industries Board or Coir Board or National Small Industries Corporation or Directorate of Handicrafts & Handloom or any other body specified by Ministry of MSME are **exempted from payment of Bid Security (EMD)** irrespective of their monetary limit, product category and capacity mentioned in their registration, **subject to submission of valid MSE registration certificate issued by appropriate authority.**
- d) For availing benefits under Public Procurement Policy (**Purchase preference**), the interested MSE Bidders must ensure that they are the **manufacturers of the tendered item(s) and registered with the appropriate authority for the said item(s).** Bids without EMD shall be rejected, if the technical offer does not include a valid copy of relevant MSE Certificate issued by appropriate authority specifying the item as per tender. Therefore, it is in the interest of such MSE Vendors to furnish a copy of complete certificate to the concerned tender handling officer of **OIL at least seven (7) days prior to the scheduled Bid Closing Date of the tender**, seeking clarification/confirmation as to whether their MSE certificate is eligible for EMD exemption or not. **Late communication in this regard and request for bid closing date extension on that plea shall not be entertained by Company.**

#### **NOTE:**

**In case of MSE/PSUs/ Govt. Bodies / eligible institutions etc., they must apply to concerned tender handling officer, Materials Department, Oil India Limited, P.O. Duliajan, Assam-786602 for waiver of EMD upto one week prior to the Bid closing date (or as amended in e-portal).**

**2.0** The tender is invited under **SINGLE STAGE-TWO BID SYSTEM**. The bidders are required to submit both the “**TECHNO-COMMERCIAL UNPRICED BID**” and “**PRICED BID**” through electronic format in the OIL’s e-Tender portal within the Bid Closing Date and Time stipulated in the e-Tender.

**2.1** Please ensure that **Technical Bid / all technical related documents related to the tender are uploaded in the RFX Information > Technical Attachment only**. The “**TECHNO-COMMERCIAL UNPRICED BID**” shall contain all techno-commercial details **except the prices**. **Please note that no price details should be uploaded in** Technical RFX Response.

**2.2** The “**PRICE BID**” must contain the price schedule and the bidder’s commercial terms and conditions. **For price upload area , please refer “NEW INSTRUCTIONS” Please refer Annex-BB for price schedule.**

**2.3** Offer not complying with above submission procedure will be rejected as per Bid Rejection Criteria mentioned in **Annexure-CCC**.

**3.0** Please note that all tender forms and supporting documents are to be submitted through OIL’s e-Procurement site only except following documents which are to be submitted manually in sealed envelope super scribed with **Tender no.** and **Due date** to **DGM-Materials, Materials Department, Oil India Limited, Duliajan - 786602, Assam** on or before the Bid Closing Date and Time mentioned in the Tender.

- a) **Original Bid Security**
- b) **Detailed Catalogue (if any)**
- c) **Any other document required to be submitted in original as per tender requirement**

All documents submitted in physical form should be signed on all pages by the authorised signatory of the bidder and to be submitted in Duplicate.

**4.0** **Benefits to Micro & Small Enterprises (MSEs) as per OIL’s Public Procurement Policy for Micro and Small Enterprises (MSEs) shall be given. Bidders are requested to go through ANNEXURE – I of MM/LOCAL/E-01/2005 for E-Procurement of Indigenous Tenders for more details.**

**5.0** Bidders are requested to examine all instructions, forms, terms and specifications in the bid. Failure to furnish all information required as per the NIT or submission of offers not substantially responsive to the bid in every respect will be at the bidders risk and may result in rejection of its offer without seeking any clarifications.

**6.0** Bidders must ensure that their bid is uploaded in the system before the tender closing date and time. Also, they must ensure that above documents which are to be submitted in a sealed envelope are also submitted at the above mentioned address before the bid closing date and time failing which the offer shall be rejected.

**7.0** Bid must be submitted electronically only through OIL’s e-procurement portal. Bid submitted in any other form will be rejected.

**8.0** **SINGLE STAGE TWO BID SYSTEM** shall be followed for this tender and only the PRICED-BIDS of the bidders whose offers are commercially and technically acceptable shall be opened for further evaluation.

9.0 a) **The Integrity Pact is applicable against this tender. Therefore, please submit the Integrity Pact document duly signed along with your quotation as per BRC. OIL shall be entering into an Integrity Pact with the bidders as per format enclosed vide Annexure DDD of the tender document. This Integrity Pact proforma has been duly signed digitally by OIL's competent signatory. The proforma has to be submitted by the bidder (along with the technical bid) duly signed (digitally) by the same signatory who signed the bid, i.e., who is duly authorized to sign the bid. Uploading the Integrity Pact with digital signature will be construed that all pages of the Integrity Pact has been signed by the bidder's authorized signatory who sign the Bid. If any bidder refuses to sign Integrity Pact or declines to submit Integrity Pact with the offer, their bid shall be rejected straightway.**

**b) The name of the OIL's Independent External Monitors at present are as under:**

**i) SHRI RAJIV MATHUR, IPS (Retd.)  
Former Director, IB, Govt. of India,  
e-Mail ID : [rajivmathur23@gmail.com](mailto:rajivmathur23@gmail.com)**

**ii) SHRI SATYANANDA MISHRA, IAS (Retd.)  
Former Chief Information Commissioner &  
Ex-Secretary, DOPT, Govt. of India  
E-Mail ID : [satyanandamishra@hotmail.com](mailto:satyanandamishra@hotmail.com)**

**iii) Shri Rudhra Gangadharan, IAS (Retd.),  
Ex-Secretary, Ministry of Agriculture  
E-mail id : [rudhra.gangadharan@gmail.com](mailto:rudhra.gangadharan@gmail.com)**

10.0 The tender shall be governed by the Bid Rejection & Bid Evaluation Criteria given in enclosed **Annexure-CCC**. However, if any of the Clauses of the Bid Rejection Criteria / Bid Evaluation Criteria (as per **Annexure-CCC**) contradict the Clauses of the tender and / or "General Terms & Conditions" as per Booklet No. MM/LOCAL/E-01/2005 for E-Procurement of Indigenous Tenders elsewhere, those in the BEC / BRC shall prevail.

11.0 To ascertain the substantial responsiveness of the bid OIL reserves the right to ask the bidder for clarification in respect of clauses covered under BRC also and such clarifications fulfilling the BRC clauses in toto must be received on or before the deadline given by the company, failing which the offer will be summarily rejected.

12.0 Please do refer the User Manual provided on the portal on the procedure How to create Response for submitting offer.

13.0 If Bank Guarantee is submitted towards 'Bid Security', then bidders have to ensure that the Bank Guarantee issuing bank indicate the name and detailed address (including e-mail) of their higher office from where confirmation towards genuineness of the Bank Guarantee can be obtained.

14.0 Bidders are requested to refer to the enclosed **Annexure – BBB** for the Taxes and Duties clauses under GST regime.

**15.0 Delivery/collection Instructions in cases where transportation is in OIL's scope:**

- (i) the suppliers shall be required to deliver the Sundry consignments of weight less than 3 (Three) Tons at the godown/office/collection point of OIL's authorized transporter in various cities.
- (ii) consignments weighing more than 3(Three) Tons shall be collected from the supplier's premises/loading points by OIL's authorized transporter.
- (iii) the names of OIL's current authorized transporters are:
  - a) M/s Western Carriers (India) Ltd.
  - b) M/s DARCL Logistics Limited

**Bidder's are requested to note the above delivery/collection instructions while submitting their offers.**

**16.0 The applicable GST on the Liquidated Damage if any, shall have to be borne by the seller. Accordingly, the Liquidated Damage shall be recovered from the seller along with applicable GST.**

**17.0 Bidders should fill-up and submit alongwith their bid an UNDERTAKING towards authenticity of information/documents furnished by them, as per enclosed ANNEXURE-K.**

**18.0 Price Breakup:**

Bidders should submit the price breakup of all the items as per “Annexure HHH” which has been uploaded under “Notes & Attachments” > “Attachments” as shown below. The price breakup “Annexure HHH” should be filled up, signed and uploaded under “Notes & Attachments” > “Attachments” only. **The filled up price breakup of all the items should not be uploaded in Technical Attachment.**

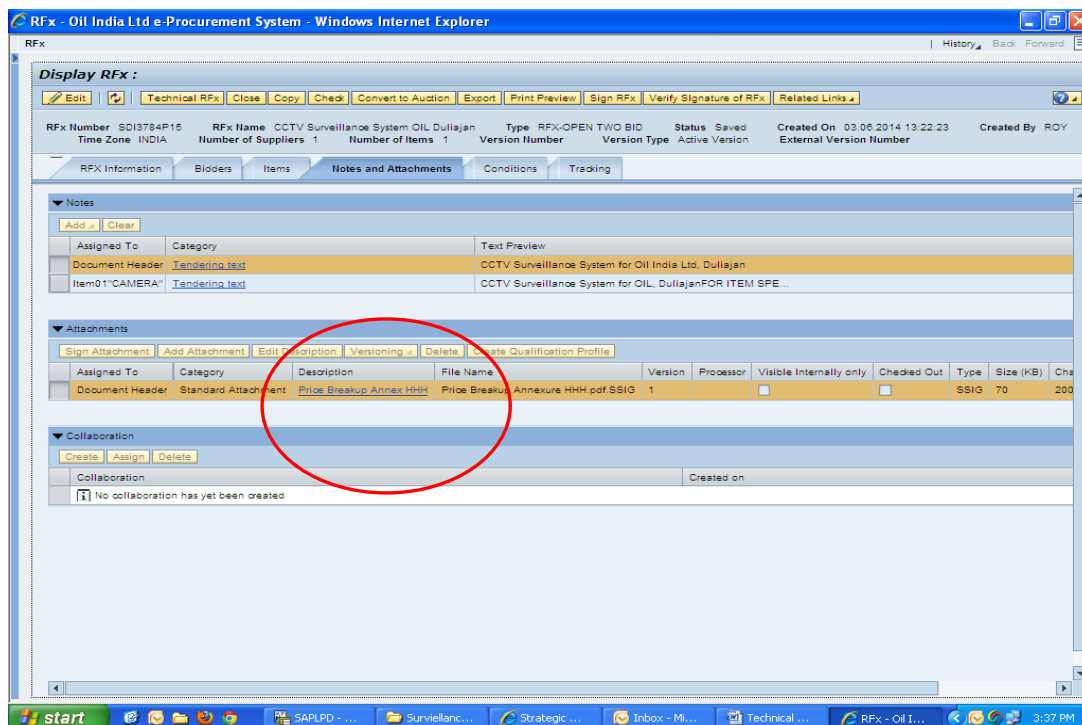

**19.0** For convenience of the qualified Bidders and to improve transparency, the rates/costs quoted by bidders against OIL's e-tenders shall be available for online viewing by such Bidders whose price bids are opened by Company. A Bidder can view item-wise rates/ costs of all other such peer bidders against the tender immediately after price bid opening, if the e-tender is floated by Company with PRICE CONDITION. In case the Price-Bid is invited by Company through attachment form under "Notes & Attachment" (i.e., NO PRICE Condition), Bidders must upload their detailed Price-Bid as per the prescribed format under "Notes & Attachment", in addition to filling up the "Total Bid Value" Tab taking into account the cost of all individual line items and other applicable charges like freight, tax, duties, levies etc. Under NO PRICE Condition (i.e., Price Bid in attachment form), the "Total Bid Value" as calculated & quoted by the Bidder shall only be shared amongst the eligible bidders and Company will not assume any responsibility whatsoever towards calculation errors/ omissions therein, if any. Notwithstanding to sharing the "Total Bid Value" or the same is whether filled up by the Bidder or not, Company will evaluate the cost details to ascertain the inter-se-ranking of bidders strictly as per the uploaded attachment and Bid Evaluation Criteria only. Online view of prices as above shall be available to the Bidders only upto seven days from the date of Price-Bid opening of the-tender.

**20.0 DISCLAIMER:** Rates/Costs shown above are as calculated/quoted by the respective Bidder. Company does not assume any responsibility and shall not be liable for any calculation error or omissions. However, for placement of order/award of contract, Company shall evaluate the cost details to determine the inter-se-ranking of Bidders strictly as per their Price-Bids and Bid Evaluation Criteria of the Tender. OIL INDIA LTD accepts no liability of any nature resulting from mismatch of "Total Bid Value" & price submitted under "Notes & Attachment" by any bidder and no claim whatsoever shall be entertained thereof.

Please do refer "**NEW INSTRUCTION TO BIDDER FOR SUBMISSION**" for the above two points and also please refer "**New Vendor Manual (effective 01.03.2019)**" available in the login Page of the OIL's E-tender Portal.

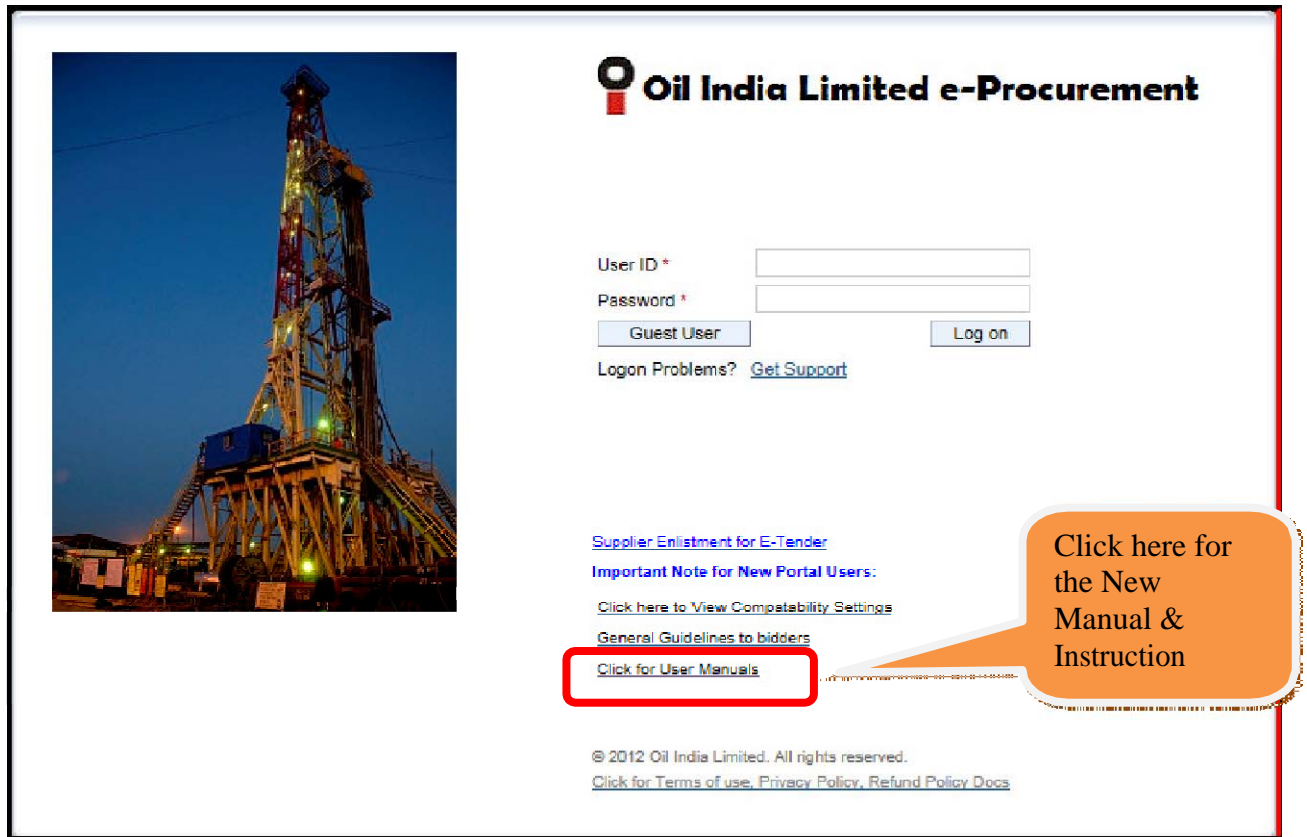

**Oil India Limited e-Procurement**

User ID \*

Password \*

Logon Problems? [Get Support](#)

[Supplier Enlistment for E-Tender](#)

**Important Note for New Portal Users:**

[Click here to View Compatability Settings](#)

[General Guidelines to bidders](#)

[Click for User Manuals](#)

© 2012 Oil India Limited. All rights reserved.  
[Click for Terms of use, Privacy Policy, Refund Policy Docs](#)

Click here for the New Manual & Instruction

**NOTE:**

**Bidders should submit their bids (preferably in tabular form) explicitly mentioning compliance / non compliance to all the terms and conditions of the NIT.**

**Yours Faithfully**

**Sd-  
(A J SARMAH)  
CHIEF MANAGER MATERIALS (IP)  
FOR : GM-MATERIALS (HoD)**



**Tender No & Date: SDI1956P20 DT: 15.07.2019**

**BID REJECTION CRITERIA (BRC) / BID EVALUATION CRITERIA (BEC)**

The following BRC/BEC will govern the evaluation of the bids received against this tender. Bids that do not comply with stipulated BRC/BEC in full will be treated as non responsive and such bids shall prima-facie be rejected. Bid evaluation will be done only for those bids that pass through the “Bid Rejection Criteria” as stipulated in this document.

Other terms and conditions of the enquiry shall be as per General Terms and Conditions vide MM/LOCAL/E-01/2005 for E-Procurement of Indigenous Tenders. However, if any of the Clauses of the Bid Rejection Criteria / Bid Evaluation Criteria (BRC / BEC) contradict the Clauses of the tender or MM/LOCAL/E-01/2005 elsewhere, those in the BRC / BEC shall prevail.

| <u>Criteria</u>  | <b>Complied / Not Complied. (Remarks if any)</b> |
|--|--|
| <p><b>1.0 BID REJECTION CRITERIA (BRC):</b></p> <p>The bid shall conform generally to the specifications, terms and conditions given in this document. Notwithstanding the general conformity of the bids to the stipulated specifications, the following requirements will have to be particularly met by the Bidders without which the same will be considered as non-responsive and rejected.</p> <p><b>A) TECHNICAL:</b></p> <p><b>1.0 Bidder’s Qualification:</b></p> <p>The bidder shall be an Original Equipment Manufacturer (OEM) of the tendered items.</p> <p><b>2.0 Bidders Experience:</b></p> <p>The bidder shall have the experience of successful execution of purchase order(s)/ contract(s) for supplying <b>12 nos.</b> of <b>similar items</b> to any <b>Oil and Gas Industry and/or E&amp;P company</b> in the last <b>05 (five) years</b> preceding the original bid closing date of this tender.</p> <p><b>Note:</b> The term “<b>Similar items</b>” means “<b>Skid Mounted Steel Tool room/ Store room/ Crew huts/ cabins / bunk houses/Drilling Rig Power Control Room</b>”.</p> <p>The <b>supporting documents</b> to be submitted with the technical bid as documentary evidence of successful execution of past supply/ contract are as follows:</p> <ul style="list-style-type: none"> <li>- <b>Copy(ies) of Purchase Order(s) / Contract document(s), and</b></li> </ul> |  |

Any of the following documents that confirms the successful execution of the order(s)/contract(s)-

- (i) Satisfactory Inspection Report (OR)
- (ii) Satisfactory Supply Completion / Installation Report (OR)
- (iii) Consignee Receipted Delivery Challans (OR)
- (iv) Central Excise Gate Pass / Tax Invoices issued under relevant rules of Central Excise / VAT/ GST (OR)
- (v) any other documentary evidence that can substantiate the satisfactory execution of each of the purchase orders cited above.

**Note:**

a) **The Purchase Order date need not be within 5 (five) years preceding original bid closing date of this tender. However, the execution of supply should be within 5 (five) years preceding original bid closing date of this tender.**

b) **Satisfactory supply completion/inspection/installation report (if submitted) should be issued on client's official letterhead with signature and stamp.**

**3.0 Delivery Period:**

Bidder should categorically confirm in the technical bid for delivery of the items within **12 months** after receipt of formal order, failing which the offer will be rejected.

**B) FINANCIAL:**

a) **Annual Financial Turnover** of the bidder during **any of preceding 03 (three) financial / accounting years from the original bid closing date** should be at least **Rs. 113.28 Lakhs.**

b) Net Worth of the firm should be Positive for preceding financial / Accounting year **(FY: 2018-2019).**

**Note -For (a) & (b):**

Considering the time required for preparation of Financial Statements, if the last date of preceding financial / accounting year falls within the preceding six months reckoned from the original bid closing date and the Financial Statements of the preceding financial / accounting year are not available with the bidder, then the financial turnover of the previous three financial / accounting years excluding the preceding financial / accounting year will be considered. In such cases, the Net worth of the previous financial / accounting year excluding the preceding financial / accounting year will be considered. However, the bidder has to submit an affidavit/undertaking certifying that 'the balance sheet/Financial Statements for the financial year ..... (As the case may be) has actually not been audited so far'.

**Note:**

a) For proof of Annual Turnover & Net worth any one of the following document must be submitted along with the bid:-

- i) A certificate issued by a practicing Chartered Cost Accountant (with

Membership Number and Firm Registration Number), certifying the Annual turnover & Net worth as per format prescribed in **ANNEXURE-J**.

OR

ii) Audited Balance Sheet along with Profit & Loss account.”

b) In case the bidder is a Central Govt. Organization/PSU/State Govt. Organization/Semi-State Govt. Organization or any other Central/State Govt. Undertaking, where the auditor is appointed only after the approval of Comptroller and Auditor General of India and the Central Government, their certificates may be accepted even though FRN is not available. However, bidder to provide documentary evidence for the same.

### **C) COMMERCIAL:**

i) Validity of the bid shall be minimum 120 days from the Bid Closing Date.

ii) Bid security:

The bid must be accompanied by Bid Security of **Rs. 4,53,100.00** in OIL's prescribed format as Bank Guarantee in favour of OIL. The Bid Security may be submitted manually in sealed envelope superscribed with Tender no. and Bid Closing date to GM-Materials, Materials Department, Oil India Limited, Duliajan- 786602, Assam on or before the Bid Closing Date and Time mentioned in the Tender. **The Bank Guarantee towards Bid Security shall be valid for 7 months from Bid closing date (i.e. upto 31.05.2020).**

**Bid Security may also be paid online on or before the Bid Closing Date and Time mentioned in the Tender.**

**If bid security in ORIGINAL of above mentioned Amount and Validity is not received or paid online within bid closing date and time, the bid submitted through electronic form will be rejected without any further consideration.**

For exemption for submission of Bid Security, please refer Clause No. 8.16 of General Terms and Conditions vide MM/LOCAL/E-01/2005 for E-Procurement of Indigenous Tenders.

**The format of Bank Guarantee towards Bid Security (Annexure – VII) has been amended to Annexure – VII (Revised) and bidders should submit Bank Guarantee towards Bid Security as per Annexure – VII (Revised) only.**

iii) Bids are invited under “Single Stage Two Bid System”. Bidders have to submit both the “Techno-commercial Unpriced Bids” and “Priced Bids” through electronic form in the OIL’s e-Tender portal within the bid Closing date and time stipulated in the e-tender. The Techno-commercial Unpriced bid is to be submitted as per scope of works and Technical specification of the tender and the priced bid as per the online Commercial bid format. For details of submission procedure, please refer relevant para of General Terms and Conditions vide MM/LOCAL/E-01/2005 for E-Procurement of Indigenous Tenders. Any offer not complying with the above shall be

rejected straightway.

iv) Performance Security:

The successful bidder shall submit Performance Security @ 10% of PO value within 30 days of receipt of the formal purchase order failing which OIL reserves the right to cancel the order and forfeit the Bid Security. Bidders should undertake in their bids to submit Performance Security as stated above.

The Performance Security shall be in the following form :

**A Bank Guarantee in the prescribed OIL's format valid for 90 days beyond delivery period and applicable warranty/guarantee period (if any).**

**The validity requirement of Performance Security is assuming despatch within stipulated delivery period and confirmation to all terms and conditions of order. In case of any delay in despatch or non-confirmation to all terms and conditions of order, validity of the Performance Security is to be extended suitably as advised by OIL.**

**However, PBG will be applicable only if value of Purchase Order exceeds Rs 5(five) lakhs.**

v) The prices offered will have to be firm through delivery and not subject to variation on any account. A bid submitted with an adjustable price will be treated as non-responsive and rejected.

vi) Bids received after the bid closing date and time will be rejected. Similarly, modifications to bids received after the bid closing date & time will not be considered.

vii) All the Bids must be Digitally Signed using "Class 3" digital certificate with Organisation's name (*e-commerce application*) as per Indian IT Act obtained from the licensed Certifying Authorities operating under the Root Certifying Authority of India (RCAI), Controller of Certifying Authorities (CCA) of India. The bid signed using other than "Class 3 with Organisation's Name" digital certificate, will be rejected.

viii) **Technical RFx Response folder is meant for Technical bid only. Therefore, No price should be given in Technical RFx Response folder, otherwise the offer will be rejected.**

ix) Price should be maintained in the "online price schedule" only. The price submitted other than the "online price schedule" shall not be considered.

**x) A bid shall be rejected straightway if it does not conform to any one of the following clauses:**

**(a) Validity of bid shorter than the validity indicated in the Tender.**

**(b) Original Bid Security not received within the stipulated date & time mentioned in the Tender.**

**(c) Bid Security with (i) Validity shorter than the validity indicated in**

**Tender and/or (ii) Bid Security amount lesser than the amount indicated in the Tender.**

**(d) In case the Party refuses to sign Integrity Pact.**

**(e) Annual Turnover of a bidder lower than the Annual turnover mentioned in the Tender.**

**NOTE: FOR CLAUSE NOS. C(ii) & C(iv) OF BID SECURITY/EMD AND PBG.**

The bidders/successful bidders are requested to advise the Bank Guarantee issuing bank to comply with the following and ensure to submit, the receipt of the copy of SFMS message as sent by the issuing bank branch, along with the original bank guarantee in OIL's tender issuing office:

The bank guarantee issued by the bank must be routed through SFMS platform as per following details:

(i) "MT 760 / MT 760 COV for issuance of bank guarantee.

(ii) "MT 760 / MT 767 COV for amendment of bank guarantee

The above message/intimation shall be sent through SFMS by the BG issuing bank branch to Axis Bank, Duliajan Branch, IFS Code - UTIB0001129, Branch Address - AXIS Bank Ltd, Duliajan Branch, Daily Bazar, Jyotinar, Duliajan, District - Dibrugarh, PIN- 786602

## **2.0 BID EVALUATION CRITERIA (BEC)**

The bids conforming to the terms and conditions stipulated in the tender and considered to be responsive after subjecting to the Bid Rejection Criteria as well as verification of original of any or all documents/ documentary evidences pertaining to BRC, will be considered for further evaluation as per the Bid Evaluation Criteria given below. The original Bid Closing Date shall be considered by OIL for evaluation of BRC criteria even in case of any extension of the original Bid Closing Date.

### **A) TECHNICAL:**

1. The manufactured product should be strictly as per OIL's tender specification.
2. Bids shall be evaluated strictly as per NIT specifications, terms and conditions.

### **B) COMMERCIAL:**

i) To evaluate the inter-se-ranking of the offers, all Taxes / Levies will be considered as per prevailing Govt. guidelines as applicable on the bid opening date. Bidders may check this with the appropriate authority before submitting their offer.

ii) Priced bids of only those bidders will be opened whose offers are found technically acceptable. The technically acceptable bidders will be informed before opening of the "priced bid".

iii) A job executed by a bidder for its own organization / subsidiary cannot be considered as experience for the purpose of meeting BEC.

|  |  |
|--|--|
| iv) To ascertain the substantial responsiveness of the bid OIL reserves the right to ask the bidder for clarification in respect of clauses covered under BRC also and such clarifications fulfilling the BRC clauses in toto must be received on or before the deadline given by the company, failing which the offer will be summarily rejected. |  |
|--|--|

**NOTE:**

**Bidders should submit their bids (preferably in tabular form) explicitly mentioning compliance / non compliance to all the terms and conditions of the NIT.**

-----XXXX-----

## TECHNICAL SPECIFICATIONS WITH QUANTITY

Tender No &amp; Date: SDI1956P20 DT: 15.07.2019

| MATERIALS DESCRIPTION   | Complied / Not Complied.<br>(Remarks if any) |
|---|--|
| <p><b><u>ITEM NO. 10</u></b></p> <p><b><u>PROCUREMENT OF CREW CABINS FOR USE AT FIELD LOCATIONS – QTY = 23 NOS</u></b></p> <p><b>SCOPE OF WORK:</b><br/>The scope of work covers manufacture and supply of crew cabin having specified dimensions complete with insulation, paneling, electric fittings, furniture and other equipments to be provided as detailed below.</p> <p><b>1.0 General design &amp; construction:</b></p> <p><b>1.1 Layout of the bunk house/crew hut:</b><br/>The crew cabin shall be portable modular design, and shall be provided with suitable lifting and handling facilities for deploying at any place for field personnel. The bunk house/crew hut shall comprise of two rooms. One room shall be for operator / crew, and the other room shall be store room with racks for materials on three walls. Throughout the front side of the bunk house there shall be a foldable verandah/corridor/platform with foldable weather shed/canopy, both with locking arrangement in folded position for convenience in transportation. The fabrication of the crew cabin should be of integral and all welded type, comprising of the skid, base frame, main shell framework, external &amp; internal cladding with insulation and other peripherals like sloping self draining roof, desired doors and windows, etc.. The dimensions are indicated in the layout diagram.</p> <p><b>1.2 Main Shell framework:</b></p> <p>1.2.1 The main corner vertical support posts should be made of 91.0 mm x 91.0 mm x 5.0 mm HF SHS YST240. All the corner posts should be suitably extended at the top with hole which should be able to hold steel forged lifting hooks for loading &amp; unloading.</p> <p>1.2.2 The top runner shall be made of 91.0 mm x 91.0 mm x 5.0 mm HF SHS YST240.</p> <p>1.2.3 The front / side / end wall frame shall be made of 60.0 mm x 60.0 mm x 4.0 mm HR SHS YST240.</p> <p>1.2.4. The roof frame (truss &amp; purlin) shall be made of 49.5 mm x 49.5 mm x 3.6 mm HF SHS YST240.</p> <p>1.2.5 The top/ceiling frame shall be made of 38.0 mm x 38.0 mm x 3.2 mm HF SHS YST240, and all cross joints should be supported by gusset plates.</p> <p><b>1.3 Base / Bottom Frame:</b><br/>The main base / bottom frame shall be fabricated and welded out of Hot Rolled Structural Steel Channels of specification ISMC 125 mm x 65 mm x 5.3 mm Grade</p> |  |

E250 A and all the inter connecting cross members shall also be of same specification steel channels duly welded lengthwise & breadth wise maintaining conveniently equal distance.

#### **1.4 Skid:**

The base / bottom frame of the cabin is to be mounted on the skid consisting of 3 (three) nos. of Hot Rolled Structural Steel Beams of specification ISMB 200 mm x 100 mm Grade E250 A. The beams should be placed at equal distance and connected with same size beam at 2000 mm apart. Base frame and skid should be made in such a way that no foundation is needed for placement of cabin. At both ends of the skid, steel pipe of size 125 mm (5") NB, Schedule 80 (141.3 mm OD X 9.53 mm thk) should be inserted & welded properly. Also, 200 mm dia x 10 mm thk MS plates should be welded properly at ends of the end pipes as stopper for sling used while loading / unloading.

#### **1.5 Verandah/Corridor/Platform:**

Cabin front should have 900 mm wide Foldable Verandah / Corridor / Platform throughout the cabin length. The verandah frame shall be made of Hot Rolled Structural Steel channel of specification ISMC 100 mm x 50 mm x 5.0 mm Grade YST240. This foldable platform should be in 02 (two) parts and have suitable locking arrangement in folding position, for convenience during transportation.

#### **1.6 Flooring:**

The entire flooring of Crew Room and Store Room shall be of MS chequered plate 6 mm thick, welded lengthwise and breadth wise properly with the base frame of the Skid. Verandah/Corridor/Platform area flooring also shall be of MS chequered plate 6 mm thick.

#### **1.7 Side and End Walls:**

The exterior cladding of the cabin shell shall be of vertical corrugated mild steel sheet. The Corrugated steel sheet should be made of Hot Rolled Mild Steel Sheet 3 mm thick, and should be welded properly to the bottom frame, corner posts, top frame and roof frame. All gaps should be sealed at edges and at seams, bottom sills to prevent ingress of insects, moisture etc.

#### **1.8 Roof:**

The roof should be of sloping type from the centre towards the walls for efficient drain of rainwater. The roof should be made of Hot Rolled Mild Steel Sheet 3 mm thick

#### **1.9 Insulation:**

75 MM thick resin bonded mineral glass wool of 2 LBS / CFT density conforming to IS 8183 should be filled in voids within the external wall and inner walls, end walls, roof with special weather proof adhesives. This glass wool slab should help in reduction in heat transmission up to 64% and should be 100% inorganic asbestos free, non-toxic and non-flammable, non-hygroscopic & vermin proof. The Side walls / end walls insulation is required only for the Crew Room and not required for the Store Room. However, the roof insulation is required in the Store Room also.

#### **1.10 Inner Paneling:**

12 MM ply wood boards as per IS 5509 manufactured by reputed manufacturer namely Kitply, Greenply, ITC or equivalent. plus 1 mm decorative laminate (Pre laminated boards) should be screwed on the side wall on the internal 'Z' sections / square tubes.



All vertical & horizontal corners should be neatly finished with aluminum anodized heavy gauge aluminum angles & flats and the vertical joints of the panels should be fixed with decorative PVC bidding patties / aluminum patties to match with the colour of panels for better aesthetic appearance. The internal paneling of the roof should be of 6 mm pre laminated boards with aluminum anodized bidding patties. The ceiling of the roof should be suspended from inside on suitable 'Z' section / angle framework. The inner paneling is required only for the Crew Room and not required for the Store Room.

### **1.11 Doors:**

1 no. Door each in Crew Room & Store Room of size 1900 mm (H) x 900 mm (W). The door should be open to inside. The vertical door-frame should be made of Hot Formed Square Hollow Section of specification 60.0 mm x 60.0 mm x 4.0 mm HF SHS YST240 welded between the base frame and the roof structure. The main door panel shall be made of MS Angle of size 40.0 mm x 40.0 mm x 5.0 mm & flat bar of size 40 mm x 5.0 mm as cross members with MS sheet 3 mm thk. Doors should have the provision of locking arrangement externally. Pellets/Curtain Brackets and rods should be provided in the door of Crew Room.

### **1.12 Windows :**

4 nos. 2 panel Windows of size 1200 mm (H) X 1200 mm (W) shall be provided as per drawing with frame made out of MS Angle of size 25.0 mm x 25.0 mm x 5.0 mm and MS sheet 3 mm thk. Anti-pilferage MS decorative grills should be provided in all the windows. Pellets/Curtain Brackets and rods should be provided in all the Windows.

### **1.13 Weather Sheds:**

1.13.1 Foldable Weather Sheds of 750 mm width & 1500 mm length shall be provided for windows on side and back. The weather shed should be made of structural frame of Cold Formed Square Hollow Section of specification 25.0 mm x 25.0 mm x 2.6 mm CF SHS and MS sheets 2 mm thick.

1.13.2 Foldable Weather Sheds of 1000 mm width & 6000 mm length shall be provided for doors & windows on front. The weather shed should be made of structural frame of Hot Formed Square Hollow Section of specification 38.0 mm x 38.0 mm x 3.2 mm HF SHS YST240, with cross members Cold Formed Square Hollow Section of specification 25.0 mm x 25.0 mm x 2.6 mm CF SHS and MS sheets 2 mm thick.

1.13.3 All Weather sheds should have suitable hook and tie/stay rod to hold them in unfolded position properly, for conveniently opening the doors & windows and protection from rain.

### **1.14 Ladder:**

A ladder should be placed outside cabin as shown in drawing for fixing up slings at top of the corner.

## **2.0 Specifications of Steel:**

- (i) Side & End walls, Roof, Doors & Windows, and Sheds : IS 1079 ( Hot Rolled Carbon Steel Sheet and Strip- Specification) (SAIL/TATA/ESSAR/JINDAL)
- (ii) Floor : IS 3502 :2009 ( Steel Chequered plate) (SAIL/TATA/ESSAR/JINDAL)
- (iii) Beams / Channels : IS 2062:2011 (Hot Rolled Medium & High Tensile Structural Steel - Specification) & IS 808 :1989 ( dimensions for hot rolled steel beam, column, channel and angle sections) (SAIL/TATA/ESSAR/JINDAL)
- (iv) Structural Rectangular / Square Hollow sections: IS 4923:1997 (Hollow steel

sections for structural use) (SAIL/TATA/ESSAR/JINDAL).

(v) Structural Tubes : IS 1161:2014 (Steel Tubes for Structural Purpose) (SAIL/TATA/ESSAR/JINDAL)

(vi) End Pipe for Skid : ASME/ANSI B36.10M (Standard Specification for Pipe, Steel, Black and Hot-Dipped, Zinc-Coated, Welded and Seamless).

Documentary evidence regarding the purchase of the above material is to be provided to OIL during the time of inspection.

### **3.0 Surface Preparation & Painting:**

The surface preparation for all steel surfaces should be pre-treated by sand or shot blasting the surface for degreasing and de-rusting followed by painting as detailed below-

3.1 Under structure / base frame :- Zinc rich epoxy primer 25-30 microns DFT followed by bituminous coating minimum 200 DFT of reputed make.

3.2 Interior :- Zinc rich epoxy primer 25-30 microns followed by High build epoxy polyamide coating 50 microns DFT

3.3 Exterior:- Zinc rich epoxy primer 25-30 microns DFT followed by High build cured epoxy resin coating 50 microns DFT followed by Acrylic aliphatic polyurethane coating 50 microns DFT .

3.4 The colour shades shall be grey.

### **4.0 Marking & Letter writing:**

4.1 User Department's Name and OIL logo shall be painted on the front side of each crew cabin, details of which will be confirmed during inspection.

4.2 OIL's Purchase order no., Manufacturer's name, serial no for identification and Approx Weight of Cabin should be weld written on each cabin.

### **5.0 Seating & Storage Arrangement:**

5.1 1 no. of desk of size 2000mm(L) x 600mm(B) x 750mm(H) and 2 nos. of bench of size 2000mm(L) x 500mm(B) x 450mm(H) shall be provided at the Crew Room. The desk frame should be made of 60.0 mm x 60.0 mm x 4.0 mm HR SHS YST240 and bench frame should be made of 49.5 mm x 49.5 mm x 3.6 mm HF SHS YST240. Desk and bench top should be made out of timber plank 35 mm Thk, smooth finished & without any gap in joint between, and fixed to the frames suitably for extreme rough conditions. The legs of table and bench should be fitted/bolted on the floor.

5.2 Store room shall have 3 nos of shelves rack of 500 mm width for storing heavy spares /tools and Crew room shall have 1 no. overhead shelf of 400 width in the crew cabin (as per drawing).

5.3 8 nos. of hooks should be provided in crew room for crew members to hang their bags/ belongings.

## **6.0 Furniture:**

Furniture should be supplied as per following.

6.1 2 nos. Steel Personnel Locker of Make Godrej / Methodex having 6 shelves and Gordian Lock shall be provided in the Crew Room. The lockers shall be fixed on the floor & wall with suitable clamp/ bolts.

Dimensions of Locker: 380 mm W \* 457 mm D \* 1830 mm H

6.2 1 no. water filter (candle type) of capacity minimum 20 litres should be supplied along with a stand. Stand should be fixed on one side of crew room and the location to be confirmed during the course of routine inspection. Make - MILTON or equivalent.

## **7.0 Welding:**

The containerized crew cabin should be of all welded steel construction using Shielded Metal Arc Welding (SMAW) using Electrode.

## **8.0 Handling facility:**

The crew cabin shall have arrangement for handling without any strain or damage under the following condition:

8.1 Lifting of the unit by crane using lifting slings; separate lifting provisions should be kept on both bottom and top of the unit so that the same can be lifted by using wire ropes slings from any one of the above provisions.

8.2 To avoid any outside surface damage caused by the wire rope slings while lifting, 50 mm angle should be welded all the four sides of the crew cabin 50 mm below the top.

## **9.0 Electrical System:**

As the crew cabin may be used within Hazardous Zone demarcated areas of mines, the electrical fittings and accessories used in the cabin shall be flameproof and weatherproof, suitable for use in Zone 1 and Zone 2 Hazardous areas of oil mines, Gas groups IIA and IIB. The following electrical items shall be provided in the Crew Room and Store Room:

### **9.1 Main Switch:**

Six (6) nos. flameproof/weatherproof ON/OFF switch to be used as Main Isolation Switch, 10A, DP, type Ex-d. Model similar to Type FSW 1134 of Baliga make. The Entry hole should suitable for 2 Nos. ¾" ET FLP double compression cable glands. Switches to be fixed as per schematic given in Annexure-E1. One switch will be mounted outside the cabin and a rain shed will be provided above it.

**9.2 Junction Box:** Two nos. flameproof junction boxes, one each in crew room and store room, 4 Way, with 8 nos. TB, type Ex-d. The Entry holes should be suitable for ¾" ET FLP double compression cable gland. Model similar to Type FPJ 414 of Baliga make.

### **9.3 Light Fittings:**

Three nos. flameproof fluorescent luminaire, type Ex-d, suitable for 1x 36 W/1x 40 W fluorescent tubes shall be provided - 2 (two) nos. for the crew room & 1 (one) no. for

the store room. Light fittings shall be ceiling mounted and arranged to provide optimal illumination. Fittings shall be provided with tubes. The Entry holes should be suitable for ¾" ET FLP double compression cable gland. Model similar to Type EPFL 140 of Baliga make.

#### **9.4 Fan :**

Two nos. Wall Mounted Flameproof Fan, type Ex-d, 60W to 100W, single phase 250V AC, 50Hz, shall be provided in the crew room at an appropriate places. Suggested Model similar to type FLP-RH-EXF-2005 of Flameproof Equipment Pvt. Ltd. make. The Entry holes should be suitable for ¾" ET FLP double compression cable gland. The size of the fans shall be within a range of 400- 450 mm (16"-18") sweep.

#### **9.5 Earth Point:**

Two cabin earth points (on the skid or body, outside) shall be provided for final termination of earth wires.

### **10.0 Specifications of Materials (Electrical):**

#### **10.1 Cable:**

All cabling from main switch to junction box, junction box to switches, switches to light fittings/fan etc. shall be EPR/PVC insulated armoured/screened multi-stranded 3/4 core flexible copper cable. Cables shall be fixed on wall/roof with the help of adequate size MS/galvanized saddles, spaced at sufficient intervals (max. interval 500 mm). All cores shall be colour coded as Red for Phase, Black for neutral and Green for earth. All wire ends shall have copper lugs of Dowell's. Cable make: Necab / CCI / Polycab / Incab / RPG.

#### **10.2 Cable glands:**

All cables shall be terminated to junction box/light fittings/fans/switch through proper sized double compression Ni-CD coated brass/SS cable glands. Party shall submit samples of gland beforehand and obtain approval for the same.

#### **10.3 Earthing:**

All light fittings and fans, junction boxes, on/off switches shall be earthed through the green earth core of the cable. All earth cores shall be looped and finally brought to the main isolation switch. From the main isolation switch, 2 nos. 8 or 10 SWG GI wire earth conductors shall be routed to the cabin skid earth points and fastened with GI fasteners.

#### **10.4 Mounting arrangement:**

As the flameproof light fittings and fans are quite heavy, suitable mounting arrangement with MS frame/other provision shall be made so that the fans and light fittings are properly secured during operation and during transportation.

#### **10.5 Make of Flameproof item:**

All Flameproof items shall be of the following makes:  
FCG Flameproof Control Gear Pvt. Ltd. /Baliga/ Sudhir / Flameproof Equipments Pvt. Ltd. (FEPL) / Flexpro Electrical Pvt. Ltd. / Pepperl & Fuchs.

### **11.0 Scope of work (Electrical):**

11.1 Bidder shall submit electrical schematic in line with Annexure-E1 with indicative bill of materials along with quotation.

11.2 On placement of PO, supplier shall take approval of the following documents from OIL before starting of the manufacturing works:

- (a) Electrical schematic drawing indicating all electrical equipment;
- (b) Bill of materials of electrical items, clearly mentioning make and model in line with the bid. Copy of Test certificates of all FLP items shall be submitted along with the Bill of Materials.

11.3 All flameproof electrical items such as fans, light fittings, junction boxes, switch, cable glands etc. shall be conforming to the requirements of relevant Indian or International Standards and duly tested and certified by CIMFR or Government Accredited Indian or International Test Houses. Bidder must submit a copy of the valid test certificate(s) approving the appliances for use in hazardous area zone-1, gas group IIA & IIB along with the bid. Bids not accompanying required test certificates for the FLP electrical items will not be considered for technical evaluation.

11.4 The electrification job shall start only after approval of documents, drawings and sample of materials by Head-Electrical in writing.

11.5 Entire electrical installation work has to be done by licensed electrician as per CEA Regulations and NEC codes. The bidder will submit the copy of the valid licenses of their work persons to OIL before start of the work.

11.6 Party shall notify OIL for inspection of electrical work at least 15 (fifteen) days in advance.

11.7 The electrical work shall be treated as complete once installation, testing & commissioning of electrical works are accepted by Head-Electrical and submission of test report for electrical works, as installed drawings & list of electrical items used, spares for lighting system by the party.

11.8 Guarantee Certificates of Fans shall be provided along with supply of materials

### **SPECIAL TERMS:**

**1.0** The bidder shall confirm that the goods, materials to be supplied shall be new, of recent make, of the best quality & workmanship. The bidder shall confirm that the materials shall be **guaranteed** for a period of 18 months from the date of dispatch or 12 months from the date of receipt at destination, whichever is earlier, against defects arising from faulty materials, workmanship or design. Defective goods / materials or parts notified by OIL to the Seller shall be replaced immediately by the Seller on FOR destination basis including payment of all taxes and duties at Seller's expense. This guarantee shall survive and hold good notwithstanding inspection, payment for and acceptance of the goods.

**2.0** Bidder must forward, along with the quotation, the detailed drawings & specifications of proven design including each and every part (main shell, base frame, skid, flooring, side & end wall, roof, weather shed/rain shed, insulation, inner paneling, doors, windows, personal lockers, shelves, desk & bench, electrical fitting/items, details of wiring etc.), prepared on the basis of drawing attached.

**3.0** The successful bidder shall make final drawings of the cabin with constructional details to meet OIL's specifications / requirements and shall submit the same for OIL's approval on placement of firm order. Final drawings should also indicate the approx. weight of each Cabin OIL will communicate the approval along with any changes/ modification, if required and the Cabins shall be constructed as per approved drawing.

**4.0 Third Party Inspection** shall be carried out by Oil India Ltd.'s approved Third Party Inspection Agency (Viz. M/S Lloyds or M/S Bureau Veritas or M/S Rites or M/S DNV or M/S IRS or M/S Tuboscope Vetco only). The scope of inspection will cover the following:

- a. General Design and dimensions,
- b. Raw Material,
- c. Welding,
- d. Quality Control,
- e. Painting,
- f. Equipment Marking,
- g. Electrical systems,
- h. Any other aspects found necessary by TPI Agency.

**5.0** Necessary test certificates for raw materials from reputed test house/ laboratory shall be submitted to the third party inspector for verification, and the verified test certificates shall be supplied to OIL in original along with supply.

**6.0** The TPI report shall be submitted along with the material supply.

**7.0** All these scope of inspection to be included in the QAP/ ITP (quality assurance plan or inspection test plan) which is to be submitted by the manufacturer and to be approved by OIL as well as the concerned TPI agency.

**8.0** **The Third Party Inspection charges should be shown separately in the offer.**

**9.0** Each crew cabin should be offered for inspection to representative of OIL at the following stages:

- a) At any time during fabrication for raw material inspection and workmanship.
- b) Inspection of wiring work by Electrical dept. of OIL before fixing of panels.
- c) On completion of the jobs before dispatching the crew cabin.

**10.0** Intimation regarding each stage inspection should be given to OIL at least 15 (fifteen) days in advance. However, inspection by OIL's engineer will remain at its discretion.

**11.0** All the electrical fittings should be tested by competent persons holding **valid electrical license**. Test certificate and Wiring Drawings should be submitted along with the Cabin.

**12. Bidders should note the following drawings enclosed alongwith the tender while submitting their offer:**

- (i) OIL/PSS/PND/006/A-Pg 1 of 3**
- (ii) OIL/PSS/PND/006/A-Pg 2 of 3**
- (iii) OIL/PSS/PND/006/A-Pg 3 of 3**
- (iv) Annexure E-1**

**Bidders should submit their bids (preferably in tabular form) explicitly mentioning compliance / non compliance to all the terms and conditions of the NIT.**

**Schematic of Electrical Wirings in Production Crew Hut**

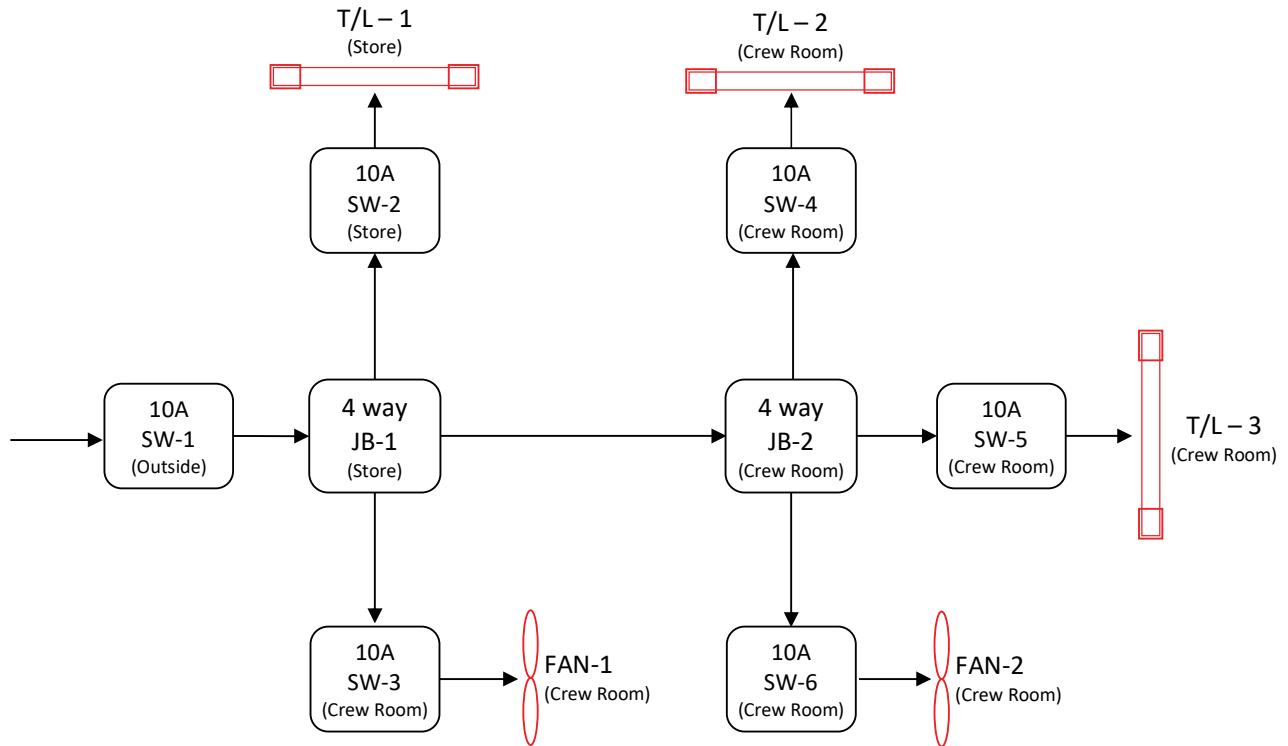

| Bill of Materials (Main Items Only) |                      |     |  |
|-------------------------------------|----------------------|-----|--|
|                                     | Item                 | Qty | Equivalent Model / Make / Remarks  |
| 1                                   | 10A FLP Switch       | 06  | Similar to Model 'FSW 1134' of M/s Baliga  |
| 2                                   | 4 Way Junction Box   | 02  | Similar to Model 'FPJ 414' of M/s Baliga   |
| 3                                   | FLP Tube Light, 36W  | 03  | Similar to Model 'EPFL-140' of M/s Baliga  |
| 4                                   | FLP Fan Wall Mounted | 02  | Similar to Model 'FLP-RH-EXF-2005 (Wall Mounted)' of M/s Flameproof Equipments Pvt. Ltd. |

**Tentative Position of Electrical Items in the Crew Hut**

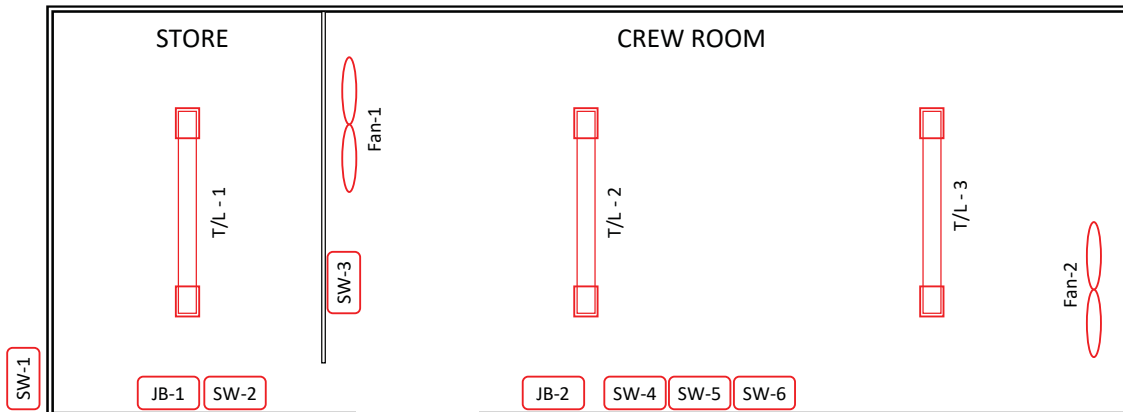



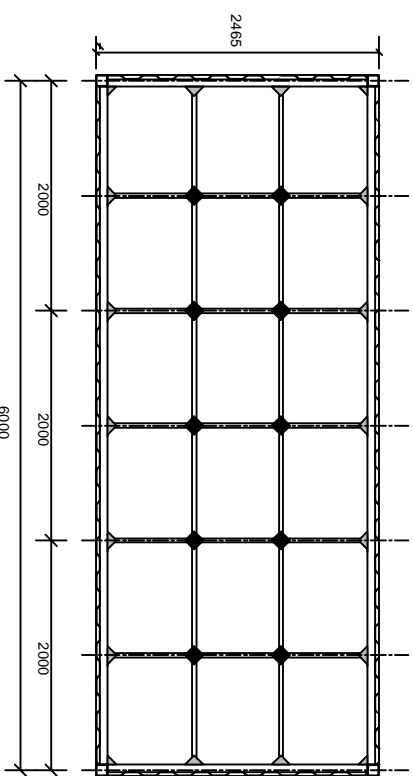
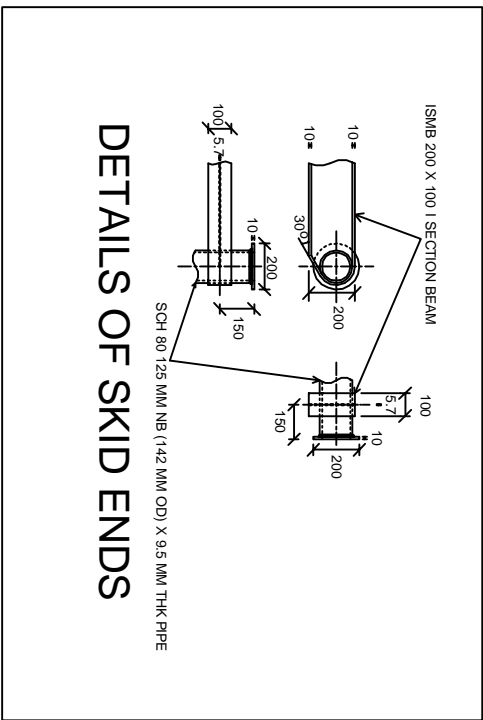

CEILING FRAME - TOP VIEW

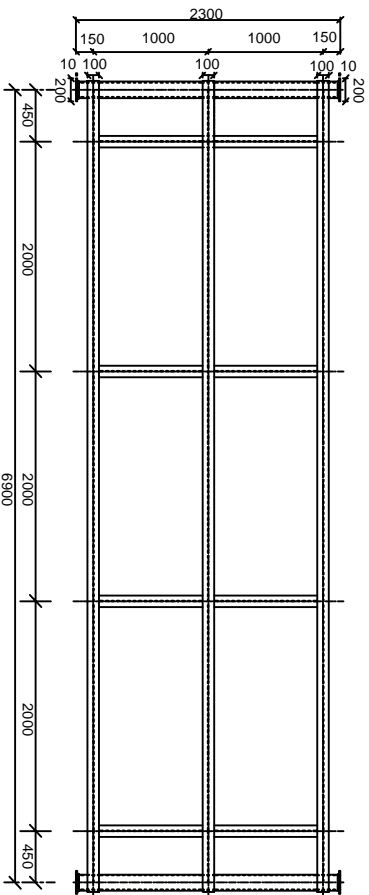

SKID - TOP VIEW

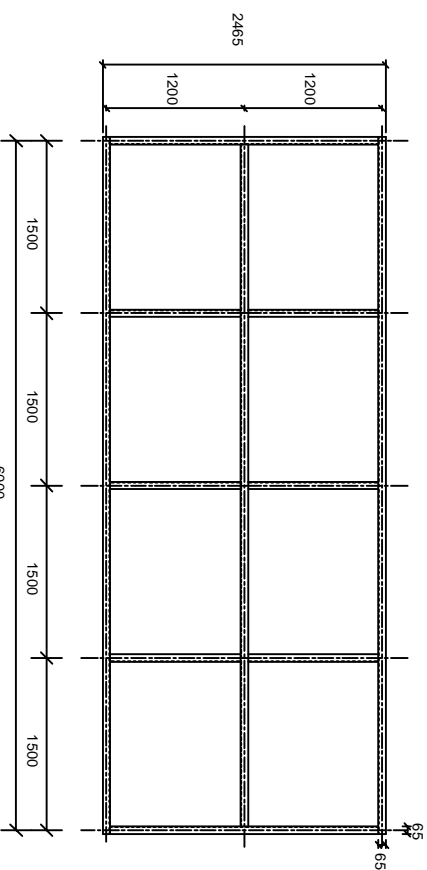

BASE FRAME - TOP VIEW

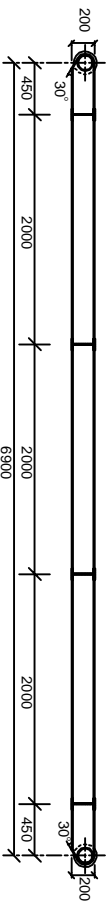

SKID - FRONT ELEVATION

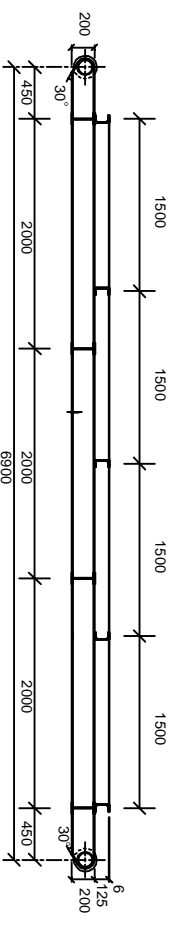

SKID WITH BASE FRAME - FRONT ELEVATION

NOTES : 1) NOT TO SCALE  
2) All dimensions are in MM

OIL INDIA LIMITED  
PSS DEPT.  
DULAJAN 786602

CREW CABIN - PRODUCTION (OIL)

DR NO

OIL/PSS/PND/006/A- Pg 1 of 3

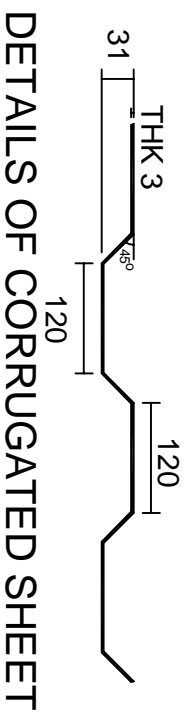

DETAILS OF CORRUGATED SHEET

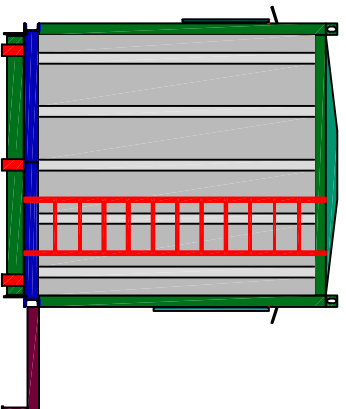

ELEVATION - LADDER END

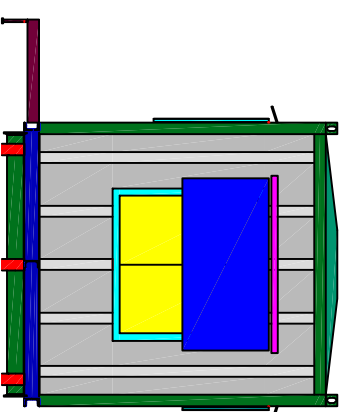

ELEVATION - WINDOW END

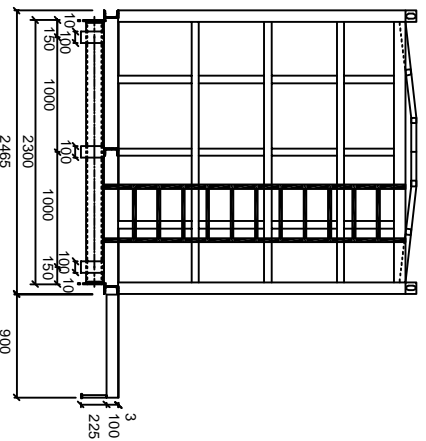

ELEVATION - LADDER END - MAIN FRAME

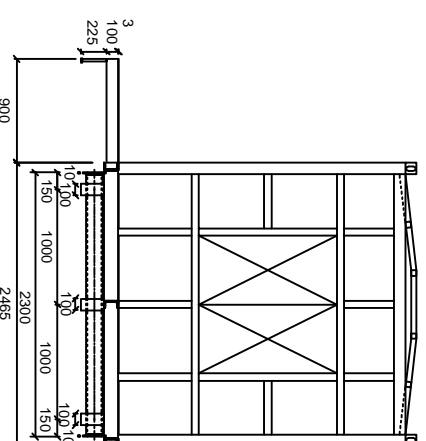

ELEVATION - WINDOW END - MAIN FRAME

NOTES : 1) NOT TO SCALE  
2) All dimensions are in MM

OIL INDIA LIMITED  
PSS DEPT.  
DULAJAN 786602

CREW CABIN - PRODUCTION (OIL)

DR NO

OIL/PSS/PND/006/A- Pg 2 of 3

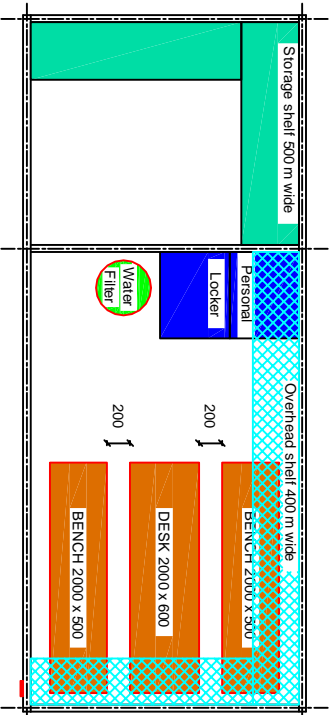

FURNITURES- TOP VIEW

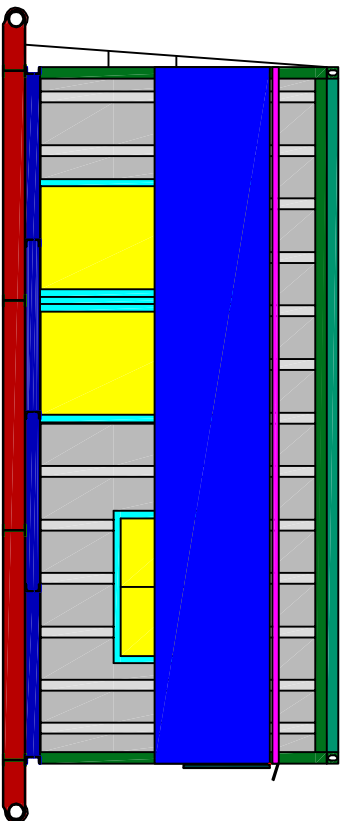

ELEVATION - FRONT

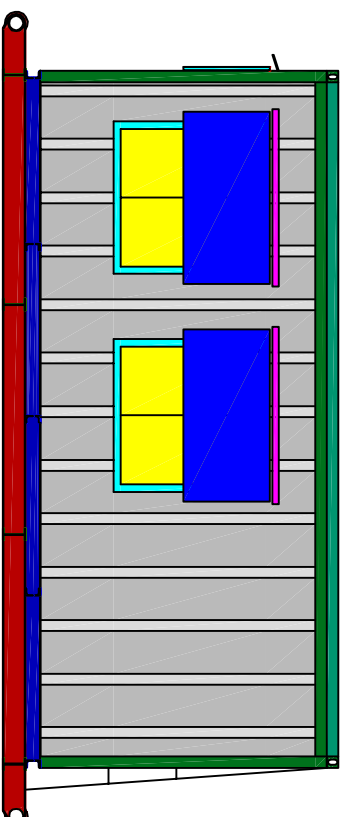

ELEVATION - BACK

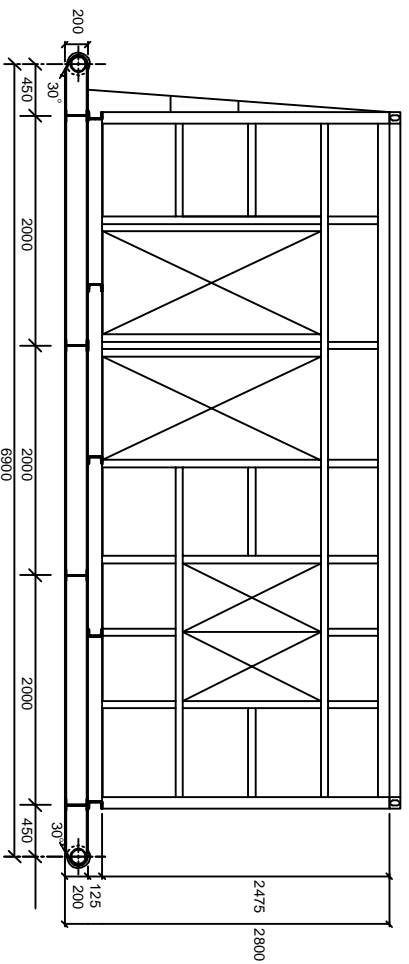

ELEVATION - FRONT - MAIN FRAME

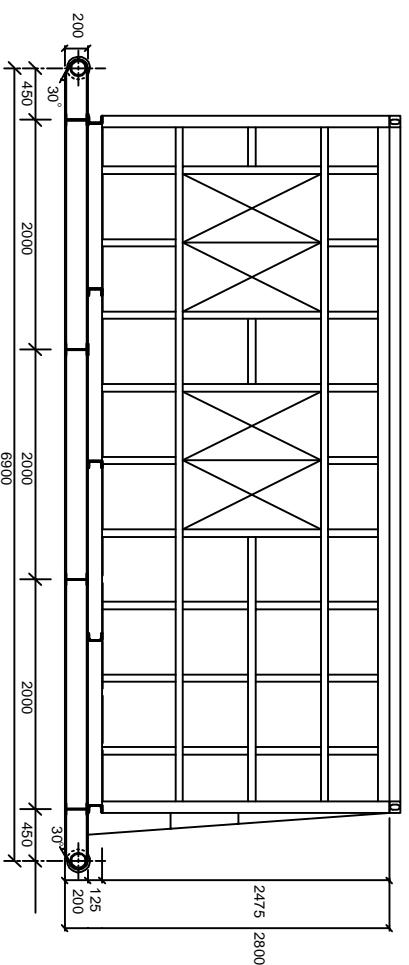

ELEVATION - BACK - MAIN FRAME

NOTES : 1) NOT TO SCALE  
2) All dimensions are in MM

OIL INDIA LIMITED  
PSS DEPTT.  
DULAJAN 786602

CREW CABIN - PRODUCTION (OIL)

DR NO

OIL/PSS/PND/006/A- Pg 3 of 3

**INTEGRITY PACT**

Between

Oil India Limited (OIL) hereinafter referred to as "The Principal"

And

(Name of the bidder).....hereinafter referred to as "The Bidder/Contractor"

**Preamble:**

The Principal intends to award, under laid down organizational procedures, contract/s for **SDI1956P20**. The Principal values full compliance with all relevant laws and regulations, and the principles of economic use of resources, and of fairness and transparency in its relations with its Bidder/s and Contractor/s.

In order to achieve these goals, the Principal cooperates with the renowned international Non-Governmental Organization "Transparency International" (TI). Following TI's national and international experience, the Principal will appoint an external independent Monitor who will monitor the tender process and the execution of the contract for compliance with the principles mentioned above.

**Section: 1 -Commitments of the Principal**

**(1)** The Principal commits itself to take all measures necessary to prevent corruption and to observe the following principles:

1. No employee of the Principal, personally or through family members, will in connection with the tender for, or the execution of a contract, demand, take a promise for or accept, for him/herself or third person, any material or immaterial benefit which he/she is not legally entitled to.
  
2. The Principal will, during the tender process treat all Bidders with equity and reason. The Principal will in particular, before and during the tender process, provide to all Bidders the same information and will not provide to any Bidder confidential/additional information through which the Bidder could obtain an advantage in relation to the tender process or the contract execution.

## **ANNEXURE- DDD**

3. The Principal will exclude from the process all known prejudiced persons.

**(2)** If the Principal obtains information on the conduct of any of its employees which is a criminal offence under the relevant Anti-Corruption Laws of India, or if there be a Page 2 of 6 substantive suspicion in this regard, the Principal will inform its Vigilance Office and in addition can initiate disciplinary actions.

### **Section: 2 -Commitments of the Bidder/Contractor**

**(1)** The Bidder/Contractor commits itself to take all measures necessary to prevent corruption. He commits himself to observe the following principles during his participation in the tender process and during the contract execution.

1. The Bidder/Contractor will not, directly or through any other person or firm, offer, promise or give to any of the Principal's employees involved in the tender process or the execution of the contract or to any third person any material or immaterial benefit which he/she is not legally entitled to, in order to obtain in exchange any advantage of any kind whatsoever during the tender process or during the execution of the contract.

2. The Bidder/Contractor will not enter with other Bidders into any undisclosed agreement or understanding, whether formal or informal. This applies in particular to prices, specifications, certifications, Subsidiary contracts, submission or non-submission of bids or any other actions to restrict competitiveness or to introduce cartelization in the bidding process.

3. The Bidder/Contractor will not commit any offence under the relevant Anticorruption Laws of India; further the Bidder/Contractor will not use improperly, for purposes of competition or personal gain, or pass on to others, any information or document provided by the Principal as part of the business relationship, regarding plans, technical proposals and business details, including information contained or transmitted electronically.

4. The Bidder/Contractor will, when presenting his bid, disclose any and all payments he has made, is committed to or intends to make to agents, brokers or any other intermediaries in connection with the award of the contract.

**(2)** The Bidder/Contractor will not instigate third persons to commit offences outlined above or be an accessory to such offences.

(3) The Bidder/Contractor signing Integrity Pact shall not approach the Courts while representing the matters to IEMs and he/she will await their decision in the matter.

**Section 3 -Disqualification from tender process and exclusion from future Contracts**

If the Bidder, before contract award has committed a transgression through a violation of Section 2 or in any other form such as to put his reliability or risibility as Bidder into question, the Principal is entitled to disqualify the Bidder from the tender process or to terminate the contract, if already signed, for such reason.

1. If the Bidder/Contractor has committed a transgression through a violation of Section 2 such as to put his reliability or credibility into question, the Principal is entitled also to exclude the Bidder/Contractor from future contract award processes. The imposition and duration of the exclusion will be determined by the severity of the transgression. The severity will be determined by the circumstances of the case, in particular the number of transgressions, the position of the transgressions within the company hierarchy of the Bidder and the amount of the damage. The exclusion will be imposed for a minimum of 6 months and maximum of 3 years.
2. The Bidder accepts and undertakes to respect and uphold the Principal's Absolute right to resort to and impose such exclusion and further accepts and undertakes not to challenge or question such exclusion on any ground, including the lack of any hearing before the decision to resort to such exclusion is taken. This undertaking is given freely and after obtaining independent legal advice.
3. If the Bidder/Contractor can prove that he has restored/recouped the Damage caused by him and has installed a suitable corruption prevention system, the Principal may revoke the exclusion prematurely.
4. A transgression is considered to have occurred if in light of available evidence no reasonable doubt is possible.
5. Integrity Pact, in respect of a particular contract, shall be operative from the date Integrity Pact is signed by both the parties till the final completion of the contract **or as mentioned in Section 9- Pact Duration whichever is later**. Any violation of the same would entail disqualification of the bidders and exclusion from future business dealings

**Section 4 -Compensation for Damages**

1. If the Principal has disqualified the Bidder from the tender process prior to the award according to Section 3, the Principal is entitled to demand and recover from the Bidder liquidated damages equivalent to Earnest Money Deposit / Bid Security.

(2) If the Principal has terminated the contract according to Section 3, or if the Principal is entitled to terminate the contract according to Section 3, the principal shall be entitled to demand and recover from the Contractor liquidated damages equivalent to Security Deposit / Performance Bank Guarantee.

3. The bidder agrees and undertakes to pay the said amounts without protest or demur subject only to condition that if the Bidder/Contractor can prove and establish that the exclusion of the Bidder from the tender process or the termination of the contract after the contract award has caused no damage or less damage than the amount or the liquidated damages, the Bidder/Contractor shall compensate the Principal only to the extent of the damage in the amount proved.

**Section 5 -Previous transgression**

1. The Bidder declares that no previous transgression occurred in the last 3 years with any other Company in any country conforming to the TI approach or with any other Public Sector Enterprise in India that could justify his exclusion from the tender process.

2. If the Bidder makes incorrect statement on this subject, he can be disqualified from the tender process or the contract, if already awarded, can be terminated for such reason.

**Section: 6 -Equal treatment of all Bidders/Contractor/Subcontractors**

1. The Principal will enter into Pacts on identical terms with all bidders and contractors.

2. The Bidder / Contractor undertake(s) to procure from all subcontractors a commitment in conformity with this Integrity Pact. The Bidder/Contractor shall be responsible for any violation(s) of the provisions laid down in this agreement/Pact by any of its sub-contractors/sub-vendors.

3. The Principal will disqualify from the tender process all bidders who do not sign this Pact or violate its provisions.

**Section: 7 -Criminal charges against violating Bidders/Contractors/ Subcontractors**

If the Principal obtains knowledge of conduct of a Bidder, Contractor or Subcontractor, or of an employee or a representative or an associate of a Bidder, Contractor or Subcontractor, which constitutes corruption, or if the Principal has substantive suspicion in this regard, the Principal will inform the Vigilance Office.

**Section: 8 -External Independent Monitor/Monitors**

1. The Principal appoints competent and credible external independent Monitor for this Pact. The task of the Monitor is to review independently and objectively, whether and to what extent the parties comply with the obligations under this agreement.
2. The Monitor is not subject to instructions by the representatives of the parties and performs his functions neutrally and independently. He reports to the Chairperson of the Board of the Principal.
3. The Contractor accepts that the Monitor has the right to access without restriction to all Project documentation of the Principal including that provided by the Contractor. The Contractor will also grant the Monitor, upon his request and demonstration of a valid interest, unrestricted and unconditional access to his project documentation. The same is applicable to Subcontractors. The Monitor is under contractual obligation to treat the information and documents of the Bidder/Contractor/Subcontractor with confidentiality.
4. The Principal will provide to the Monitor sufficient information about all meetings among the parties related to the Project provided such meetings could have an impact on the contractual relations between the Principal and the Contractor. The parties offer to the Monitor the option to participate in such meetings.
5. As soon as the Monitor notices, or believes to notice, a violation of this agreement, he will so inform the Management of the Principal and request the Management to discontinue or heal the violation, or to take other relevant action. The monitor can in this regard submit non-binding recommendations. Beyond this, the Monitor has no right to demand from the parties that they act in a specific manner, refrain from action or tolerate action. However, the Independent External Monitor shall give an opportunity to the bidder / contractor to present its case before making its recommendations to the Principal.
6. The Monitor will submit a written report to the Chairperson of the Board of the Principal within 8 to 10 weeks from the date of reference or intimation to



**ANNEXURE- DDD**

him by the 'Principal' and, should the occasion arise, submit proposals for correcting problematic situations.

7. If the Monitor has reported to the Chairperson of the Board a Substantiated suspicion of an offence under relevant Anti-Corruption Laws of India, and the Chairperson has not, within reasonable time, taken visible action to proceed against such offence or reported it to the Vigilance Office, the Monitor may also transmit this information directly to the Central Vigilance Commissioner, Government of India.

8. The word 'Monitor' would include both singular and plural.

**Section:9 -Pact Duration**

This Pact begins when both parties have legally signed it. It expires for the Contractor 12 months after the last payment under the respective contract, and for all other Bidders 6 months after the contract has been awarded.

If any claim is made/ lodged during this time, the same shall be binding and continue to be valid despite the lapse of this pact as specified above, unless it is discharged/determined by Chairperson of the Principal.

**Section:10 -Other provisions**

1. This agreement is subject to Indian Law. Place of performance and jurisdiction is the Registered Office of the Principal, i.e. New Delhi. The Arbitration clause provided in the main tender document / contract shall not be applicable for any issue / dispute arising under Integrity Pact.

2. Changes and supplements as well as termination notices need to be made in writing. Side agreements have not been made.

3. If the Contractor is a partnership or a consortium, this agreement must be, signed by all partners or consortium members.

4. Should one or several provisions of this agreement turn out to be invalid, the remainder of this agreement remains valid. In this case, the parties will strive to come to an agreement to their original intentions.

A J SARMAH  
CMM (IP)

.....  
**For the Principal**

.....  
**For the Bidder/Contractor**

Witness 1: .....

Witness 2: .....

Place. DULIAJAN  
Date . 16.07.2019

**Technical Bid Checklist****Annexure-EEE**

| Tender No.      |  |   |  |
|-----------------|--|---|--|
| Bidder's Name : |  |   |  |
|                 |  | <b>Compliance by Bidder</b>                             |  |
| Sl. NO.         | BEC / TENDER REQUIREMENTS  | Indicate 'Confirmed' / 'Not Confirmed' / Not applicable | Indicate Corresponding page ref. of unpriced bid or Comments |
| 1               | Confirm that validity has been offered as per NIT.   |   |  |
| 2               | Confirm that Bid Security / Earnest Money has been submitted as per NIT (Wherever Applicable) ?  |   |  |
| 3               | Confirm that you shall submit Performance security (in the event of placement of order) (Wherever Applicable) ?  |   |  |
| 4               | Confirm that duly signed Integrity Pact has been submitted as per NIT (Wherever Applicable) ?  |   |  |
| 5               | Confirm that you have submitted documentary evidence of successfully executing one Purchase order as stipulated in NIT in any of the preceding 5 financial years (*) |   |  |
| 6               | Confirm that you have submitted Balance Sheet and Profit and Loss Account of any of the preceding 3 financial years certified by a chartered accountant.             |   |  |
| 7               | Confirm that the bid has been signed using Class 3 digital certificate with Organisation's Name as per NIT.  |   |  |
| 8               | Confirm that you have not taken any exception/deviations to the NIT .  |   |  |

NOTE: Please fill up the greyed cells only.

(\*) Purchase Orders along with copies of any of the documents in respect of satisfactory execution of the Purchase Orders should be submitted – (i) Satisfactory Inspection Report (OR) (ii) Satisfactory Supply Completion / Installation Report (OR) (iii) Consignee Received Delivery Challans (OR) (iv) Central Excise Gate Pass / Tax , Invoices issued under relevant rules of Central Excise / VAT (OR) (v) any other documentary evidence that can substantiate the satisfactory execution of the purchase order cited above.

**Response Sheet**

Annexure-FFF

|              |
|--------------|
| Tender No.   |
| Bidders Name |

**Bidders Response Sheet**

| SI No. | Description   | Remarks |
|--------|---|---------|
| 1      | Place of Despatch   |         |
| 2      | Whether Freight charges have been included in your quoted prices  |         |
| 3      | Whether Insurance charges have been included in your quoted prices  |         |
| 4      | Make of quoted Product  |         |
| 5      | Offered Validity of Bid as per NIT  |         |
| 6      | Bid Security Submitted (if applicable)  |         |
| 6      | Details of Bid Security Submitted to OIL (if applicable)  |         |
|        | a) Bid Security Amount (In Rs):   |         |
|        | b) Bid Security Valid upto:   |         |
| 7      | Whether you shall submit Performance Security in the event of placement of order on you (if applicable)   |         |
| 8      | Integrity Pact Submitted (if applicable)  |         |
| 9      | Whether you have submitted documentary evidence of successfully executing one Purchase order as stipulated in NIT in any of the preceding 5 financial years (*) |         |
| 10     | Whether you have submitted Balance Sheet and Profit and Loss Account of any of the preceding 3 financial years certified by a chartered accountant.             |         |
| 11     | Delivery Period in weeks from placement of order  |         |
| 12     | Complied to Payment terms of NIT (if applicable) otherwise to Standard Payment Terms of OIL or not.   |         |
| 13     | If bidder is MSE whether you have quoted your own product   |         |
| 14     | If Bid security submitted as Bank Guarantee, Name and Full Address of Issuing Bank including Telephone, Fax Nos and Email id of branch manager                  |         |

**NOTE: Please fill up the greyed cells only.**

(\*) Purchase Orders along with copies of any of the documents in respect of satisfactory execution of the Purchase Orders should be submitted – (i) Satisfactory Inspection Report (OR) (ii) Satisfactory Supply Completion / Installation Report (OR) (iii) Consignee Receipted Delivery Challans (OR) (iv) Central Excise Gate Pass / Tax , Invoices issued under relevant rules of Central Excise / VAT (OR) (v) any other documentary evidence that can substantiate the satisfactory

**(TO BE FILLED UP BY ALL THE VENDOR IN THEIR OWN LETER HEAD)  
(ALL FIELDS ARE MANDATORY)**

Tender No. :.....  
Name of Beneficiary :M/s.....  
Vendor Code :.....  
Address :.....  
.....  
Phone No. (Land Line) :.....  
Mobile No. :.....  
E-mail address :.....  
Bank Account No. (Minimum  
Eleven Digit No.) :.....  
Bank Name :.....  
Branch :.....  
Complete Address of your  
Bank :.....  
IFSC Code of your Bank  
a) RTGS :.....  
b) NEFT :.....  
PAN :.....  
VAT Registration No. :.....  
CST Registration No. :.....  
Service Tax Registration No. :.....  
Provident Fund Registration :.....

**I/We confirm and agree that all payments due to me/us from Oil India Limited can be remitted to our above mentioned account directly and we shall not hold Oil India Limited responsible if the amount due from Oil India Limited is remitted to wrong account due to incorrect details furnished by us.**

Office Seal

.....  
Signature of Vendor

**Counter Signed by Banker:  
Seal of Bank:**

**Enclosure: Self attested photocopies of the following documents-**

- 1) PAN Card
- 2) VAT Registration Certificate
- 3) Service Tax Registration
- 4) CST Registration
- 5) Provident Registration Certificate
- 6) Cancelled cheque of the bank account mentioned above (in original).
- 7) Bank Statement not older than 15 days on the date of submission.