



## FORWARDING LETTER

**Subject: Tender No. SDG1901P23/07 dated 27.10.2022 for procurement of 37.1/2" ROTARY TABLE. Qty = 1 Nos.**

Dear Sir/Madam,

- OIL INDIA LIMITED (OIL)** is a premier National Oil Company engaged in the business of Exploration, Production and Transportation of Crude Oil and Natural gas. A Navratna Company under the Ministry of Petroleum and Natural gas, Government of India (GOI), with its Headquarters at Duliajan, Assam. Duliajan is connected by Air with nearest Airport at Dibrugarh, 45 km away.
- In connection to its operations, OIL invites **INTERNATIONAL COMPETITIVE BIDS** from competent and experienced bidders through OIL's e-procurement site for the items mentioned below. One complete set of Bid Document for above is uploaded in OIL's e-procurement portal. You are invited to submit your most competitive bid on or before the scheduled bid closing date and time through OIL's e-procurement portal. For your ready reference, few salient points of the Tender are highlighted below:

E-Tender No.	:	<b>SDG1901P23/07 dated 27.10.2022</b>
Type of Bidding	:	<b>SINGLE STAGE TWO BID SYSTEM</b>
Bid Closing Date & Time	:	As mentioned in OIL's E- procurement portal at 11:00 HRS.
Technical Bid Opening Date & Time	:	As mentioned in OIL's E- procurement portal at 14:00 HRS.
Price Bid Opening Date & Time	:	To be decided later and shall be intimated separately to the technically qualified bidders only.
Bid Security Amount	:	Not applicable ( <i>Bid Security Declaration to be submitted</i> )
Bid Security Validity	:	Not applicable
Bid Submission Mode	:	Bids must be uploaded online in OIL's E-procurement portal
Bid Opening Place	:	Office of GM-Materials, Materials Department, Oil India Limited, Duliajan - 786602, Assam, India.
Bid Validity	:	Bid should be valid for <b>120 days</b> from actual bid closing date.

	Performance Guarantee	:	Applicable @ 3% of Order value
	Integrity Pact	:	Applicable
	MSE Purchase Preference	:	Applicable
	PPLC Purchase Preference	:	Applicable
	Preference to domestically manufactured Iron and Steel product (DMI&SP Policy)	:	Not Applicable
	Document Verification	:	Not Applicable (Detailed in clause 47 of under CC: General Notes to Bidders of Annexure - A)
	Restrictions on procurement from a bidder of a country which shares a land border with India	:	Applicable
	Contact Details	:	Tuhin Roy Chief Manager Materials (FD) E-MAIL: <a href="mailto:tuhin_roy@oilindia.in">tuhin_roy@oilindia.in</a> PHN: 0374-2808614
	E-Tender technical Support	:	TEL: 0374- 2804903, 2807171, 2807192, E-MAIL: <a href="mailto:erp_mm@oilindia.in">erp_mm@oilindia.in</a>
	Bids to be addressed to	:	GM-Materials, Materials Department, Oil India Limited, Duliajan -786602, Assam, India.

**LIST OF ANNEXURES & PROFORMA**

PART - A	Annexure - A	:	AA: Item Details and Quantities of Item BB: Deleted
	Annexure - B	:	AA: Technical Specifications BB: Special Notes to Bidders
	Annexure - C	:	Bid Rejection Criteria/Bid Evaluation Criteria
	Annexure - D	:	Technical & Commercial Check List
	Annexure - E	:	Bid Evaluation Matrix (Technical)
	Annexure - F	:	Bid Evaluation Matrix (Bid Rejection Criteria)
	Annexure - G(i)	:	Price Bid Format/Price Schedule - For Domestic Bidders (Attached in 'Notes & Attachments')
	Annexure - G(ii)	:	Price Bid Format/Price Schedule - For Foreign Bidders
PART - B	Annexure - H	:	AA: General Notes to Bidders BB: Additional Notes to Bidders
	Appendix - A1	:	Purchase Preference (linked with local

		content) policy
Appendix - A2		<del>Policy for providing preference to Domestically Manufactured Iron &amp; Steel Products (DMI &amp; SP)</del>
Appendix - A3		<del>Amendment to DMI&amp;SP vide Gazette notification No. S 13026/1/2020 IDD dated 31.12.2020, Ministry of Steel for certain amendment to DMI&amp;SP policy</del>
Appendix - A4		Restrictions on procurement from a bidder of a country which shares a land border with India.
General Terms & Conditions	:	General Terms & Conditions" for e-Procurement as per Booklet No. MM/GLOBAL/E-01/2005 for E-procurement (ICB Tenders).
Proforma - 1	:	Format for Bid Security Declaration
Proforma - 2	:	Format for Integrity Pact
Proforma - 3	:	Format for Performance Security
Proforma - 4	:	Format for undertaking towards submission of authentic information/ documents
Proforma - 5	:	Format for undertaking towards compliance of restriction on procurement from a bidder of a country which shares a land border with India
Proforma - 6		Form 10F
Proforma - 7	:	Format for No Business Connection or Permanent Establishment Certificate
Proforma - 8	:	Format for undertaking towards compliance of Financial Criteria
Proforma - 9	:	Format for Annual Turn Over and Networth Certificate
Proforma - 10	:	Format for Corporate Guarantee towards Financial Standing

3.0 OIL looks forward to your active participation in the Tender.

Thanking You  
Yours Faithfully,  
OIL INDIA LIMITED

**(Tuhin Roy)**  
**Chief Manager Materials (FD)**  
**For GM-Materials (HoD)**  
**For Resident Chief Executive**

PART - A

Annexure - A	: AA: Item Details and Quantities of Item BB: Deleted
Annexure - B	: AA: Technical Specifications BB: Special Notes to Bidders
Annexure - C	: Bid Rejection Criteria/Bid Evaluation Criteria
Annexure - D	: Technical & Commercial Check List
Annexure - E	: Bid Evaluation Matrix (Technical)
Annexure - F	: Bid Evaluation Matrix (Bid Rejection Criteria)
Annexure - G(i)	: Price Bid Format/Price Schedule - For Domestic Bidders ( <i>Attached in 'Notes &amp; Attachments'</i> )
Annexure - G(ii)	: Price Bid Format/Price Schedule - For Foreign Bidders

**ANNEXURE – A**

**AA: ITEM DETAILS & QUANTITY OF ITEMS**

<b>SL NO.</b>	<b>ITEM DESCRIPTION</b>	<b>QUANTIT Y</b>
<b>10</b>	<b>37.1/2" ROTARY TABLE</b>	<b>1 Nos.</b>

**BB: PRE-BID CONFERENCE:**

1.0 Not Applicable.

**TECHNICAL EVALUATION MATRIX**  
**(TO BE FILLED IN BY BIDDER DULY SIGNED)**

**ANNEXURE - B - ITEM SPECIFICATION**

Clause No.	DESCRIPTION	BIDDER'S RESPONSE		
		(Complied / Not Complied / Confirmed / Not Confirmed / Deviation / Not Applicable)	Bidder's offer (Specification/ parameter etc.)	Reference of Document name / Serial no / Page no etc of their bid for documentary evidence to support the offer / compliance
	Item 1- 37.1/2" (953 MM) ROTARY TABLE (FOR OPERATION IN ELECTRICAL IRD – Independent Rotary Drive) DESIGNED, MANUFACTURED, TESTED, CERTIFIED AND MONOGRAMMED AS PER API SPECIFICATION 7K (LATEST EDITION) ALONGWITH ACCESSORIES AS PER THE			

	FOLLOWING:  <b>QUANTITY - 01 NO</b>			
<b>A.0</b>	<b>DESIGN FEATURES:</b>			
<b>A.1</b>	High Capacity Roller Bearing			
<b>A.2</b>	Pinion Shaft on Side			
<b>A.3</b>	Oil Lubricated Pinion, Gear & Bearing			
<b>A.4</b>	Cascade Lubrication from Central Oil Reservoir			
<b>A.5</b>	Selective Direct Table Locks			
<b>A.6</b>	Rectangular Housing			
<b>A.7</b>	Rectangular anti-slipping Rotary Table Cover			
<b>A.8</b>	Effective Mud & Oil Sealing			
<b>A.9</b>	The rotary table needs to be engaged to rotary table beam with pad eyes pin shafts; as per given diagram.			
<b>B.0</b>	<b>PERFORMANCE SPECIFICATIONS:</b>			
<b>B.1</b>	Maximum Static Load capacity: 650 Tons (590 Tonnes)			
<b>B.2</b>	Maximum Table speed: 350 RPM			
<b>B.3</b>	Maximum Torque: 37,800 ft-lbs			
<b>C.0</b>	<b>GENERAL SPECIFICATIONS:</b>			
<b>C.1</b>	Maximum Table Opening Diameter: 37.1/2" (953 mm)			
<b>C.2</b>	Nominal distance between center of Rotary Table & center of inner row of sprocket teeth: <b>53.1/4" (1353 mm)</b>			
<b>C.3</b>	Bottom of the base to Centre line of pinion: 13" (330 mm)			

C.4	<p>Pinion Shaft extension details (Straight Pinion Shaft) :</p> <p>i Diameter: Approx. 4.15/16 " (125.41 mm)</p> <p>ii Length: Approx. 7.3/4" (196.85 mm)</p> <p>iii Keyway (width x depth): Approx. 1.1/4" (31.75 mm) x 7/16" (11.11 mm)</p>			
C.5	Gear ratio: (3.6 to 4.05) : 1			
C.6	<p><b>C.6 Major Dimensions:</b> (Annexure BB)</p> <p><b>C.6.a</b> Width across table cover: <b>70.3/4"</b> (1797 mm)</p> <p><b>C.6.b</b> Width across base: <b>56.3/4"</b> (1442 mm)</p> <p><b>C.6.c</b> Overall length (from guard end to end of pinion shaft): <b>95.3/4"</b> (2432 mm)</p> <p><b>C.6.d</b> Length across guards: <b>86"</b> (2184 mm)</p> <p><b>C.6.e</b> Length of base (table base): <b>83"</b> (2108 mm)</p> <p><b>C.6.f</b> Overall height: <b>28.1/4"</b> (718 mm)</p>			
C.7	<p><b>Locking device, three position:</b></p> <p>C.7.a NEUTRAL - To permit free turning of table in both direction</p> <p>C.7.b LOCK - To lock the turning of the table in either direction</p> <p>C.7.c RATCHET - To permit the turning of table in clockwise direction only</p>			
C.8	Rotary Table should have necessary oil level dip stick, filter pipe & drain plug.			
C.9	Rotary Table should be complete with Drive Sprocket consisting of Sprocket Hub and			



	Quadruple Tooth Sprocket with 37 teeth & 1.5" (38.10 mm) pitch, installed on pinion shaft. Quantity: 01(One) Set.			
<b>C.10</b>	Operating Temperature: Standard			
<b>D.0</b>	<b>ACCESSORIES:</b>			
<b>D.1</b>	MASTER BUSHING - QTY: 1 (ONE) NO One (01) no of Split Body Pin drive Master Bushing as per API spec 7K for 37.1/2" Rotary Table, complete with 1 (one) no of API No. 3 Insert bowl, (2-3/8" to 8-5/8"), and 1(one) no of Lifting sling.			
<b>D.2</b>	SPLIT CASING BUSHING - QTY: (FOUR) NOS. : Four (04) nos. of Split Casing Bushing with Lifting Sling as per API spec 7K for 37.1/2" Rotary Table for handling <b>20"</b> , <b>13.3/8"</b> , <b>9.5/8"</b> and <b>7"</b> Casings.			
<b>D.3</b>	Spare Sprocket Hub along with quadruple tooth sprocket 37 Teeth & 1.5" (38.10 mm) pitch. Quantity: 01(One) No.			
	<b>GENERAL NOTES FOR BIDDERS:</b>			
1	The items shall be brand new, unused & of prime quality. Bidder shall warrant (in the event of an order) that the product supplied will be free from all defects & fault in material, workmanship & manufacture and shall be in full conformity with ordered specifications. This clause shall be valid for 18 (eighteen) months from date of dispatch/shipment or 12 (twelve) months from the date of commissioning whichever is earlier. The defective materials, if any, rejected by us shall be replaced by the supplier at their own expense. Bidders must confirm the same while quoting.			
2	The Bidder should indicate the name of manufacturer, country of origin and place of			

	dispatch of their offered Rotary Table and accessories.			
3	The Bidder must provide detailed specifications against all the tender parameters including the make and model of the offered Rotary Table and forward relevant product catalogue, literature, detailed drawings of the items and parts list along with the quotation in support of their offer.			
4	The Bidder must confirm that the item will be designed, manufactured, tested, certified and monogrammed as per API spec 7K (latest edition) & SR-3. Bidders are required to forward currently valid API Spec. 7K certificate of the manufacturer along with the quotation.			
5	Necessary marking on the item shall be done as per API Spec. 7K (latest edition). Additionally, purchase order number and manufacturer's name have to be stamped on the body of the item. Bidder should categorically confirm the same while quoting.			
6	Bidder should forward a list of recommended spares for 02 (two) years operation for the quoted Rotary Table indicating part numbers, quantity & unit price separately along with the quotation in the commercial bid and categorically confirm the same in the technical bid (price should not be mentioned in the technical bid). The price should remain valid for at least 02 (two) years. However, <b>the cost of these spares will not be considered for bid evaluation purpose.</b>			
7	Additionally, the Bidder shall submit an un-priced list of recommended spares for 02 (two) years operation against the quoted Rotary Table, indicating year wise requirement, part numbers and quantity along with the technical bid. <b>These spares will not be</b>			

	<b>considered for bid evaluation purpose.</b>			
8	In the event of order, the supply must include the Manufacturing Data book pertaining to the item as per API Spec. 7K (latest edition), SR-3 in hard copy format inclusive of statement of compliance, NDE records, test certificates as applicable. Bidder should categorically confirm while quoting.			
9	The Bidder should confirm to provide along with the supply, 02(two) sets of Operation, service and maintenance manual indicating assembling and disassembling procedures, drawing and spare parts list with part numbers of the quoted Rotary Table.			
10	Any deviation(s) from the tender specification should be clearly highlighted specifying justification in support of deviation			
11	Bidder shall submit the duly filled in and signed "Technical check list" and "Evaluation Sheet for BEC-Technical & Evaluation Sheet for Technical Specification" along with the technical bid.			

\*\*\*\*\*

**ANNEXURE - C**

**BID EVALUATION CRITERIA (BEC)/BID REJECTION CRITERIA (BRC)**

The bids shall conform to the specifications and terms & conditions given in the Tender. Bids shall be rejected in case the items offered do not conform to the required parameters stipulated in the technical specifications and to the relevant international/national standards wherever stipulated. Notwithstanding the general conformity of the bids to the stipulated specifications and terms & conditions, the following requirements must be particularly met by the bidders, without which the offer shall be considered as non-responsive and rejected:

**BID REJECTION CRITERIA (BRC):**

**(A.1) BRC-TECHNICAL:**

1.0 The Rotary Table shall be designed, manufactured, tested, monogrammed and certified as per API Spec. 7K (latest edition), SR-3.

2.1.1.A The bidder should have an experience of minimum 05 (five) years in manufacturing the tendered item conforming to API Spec. 7K certification on continuous basis. For this purpose, the period reckoned shall be prior to the date of original bid closing date of the tender.

Copies of API Spec. 7K certificates, having authorization for manufacturing of Rotary Table, for the last 05 (five) years (on continuous basis without having any breaks in between), must be submitted along with the techno-commercial bid. Bid without copies of valid API Spec. 7K certificates or without the required API authorization for manufacturing of Rotary Table or with a break in the continuity of the API certification, will be rejected.

2.1.1.B For Indian Bidders who is manufacturer of the tendered items (OEM of the Tendered Items), with valid API 7K certificate having authorisation for manufacturing Rotary Table covering a period of at least 10 years in last 15 years preceding the original bid closing date of this tender must be submitted along with the techno commercial bid.

All other terms of this tender remain same for both Indian and Foreign bidder.

Note:

a) In case, renewal process of the API 7K certificate of the manufacturer is in progress at the time of bidding, then the manufacturer should furnish a letter from API to this effect that, their certification is under examination for renewal with API

and is authorized to manufacture and monogram the items as per API Spec. 7K, till the renewed license is issued.

b) The bidder shall also submit an undertaking that, any delay in renewal of their API 7K certificate, shall not affect the stipulated delivery schedule of the tender / purchase order.

2.1.2 Additionally, the bidder should also have API Spec. Q1 or ISO 9001 certification for manufacturing of Rotary Tables. Copy(s) of API Spec Q1 or ISO 9001 certificate, valid as on original bid closing date of the tender, should be submitted along with the bid, without which their bid will be rejected.

2.2 The bidder should have manufactured and supplied minimum 01 (one) number of Rotary Table of same or higher size and same or higher capacity, to E&P Companies/ Drilling Contractors/ Drilling Service Providers during the last 10 (years) as on original bid closing date of the tender (either by themselves or through their sole selling agent/ distributor/ dealer/ supply house).

Documentary evidence in respect of manufacturing and supplying the above mentioned item(s), should be submitted along with the technical bid, in the form of copies of relevant Purchase Orders and copies of any of the following documents, in respect of satisfactory execution of each of those Purchase Orders, failing which the bid will be rejected:

- I. Signed and sealed Satisfactory supply / completion / installation report (OR)
- II. Bill of Lading (OR)
- III. Consignee receipted delivery receipt/ challan (OR)
- IV. Central Excise Gate Pass/Tax Invoice issued under relevant rules of Central Excise/Vat. (OR)
- V. Commercial Invoice/ Payment Invoice

Note:

a) The Purchase Order date(s) need not be within 10 (years) preceding original bid closing date of this tender. However, the execution of supply should be within 10 (years) preceding the original bid closing date of this tender.

b) Original Bid Closing Date shall be considered by OIL for evaluation of BRC Criteria in case of any extension of the bid closing date.

c) Satisfactory supply/ completion/ installation report should be issued on Client's official letterhead with signature and stamp. Originals to be produced for verification on demand of OIL.

d) In case, for supplementing the manufacturer's supply experience criteria, the manufacturer submits Purchase Order(s) and relevant documents which are through their sole selling agent/ distributor/ dealer/ supply house, then following additional documents are also to be submitted:

Copies of signed Purchase Order(s)/ Contract agreement(s) between the manufacturer and the sole selling agent/ distributor/ dealer/ supply house and copies of any of the following documents in respect of satisfactory execution of each of those Purchase Order(s)/ Contract agreements(s):

- I. Bill of Lading (OR)
- II. Commercial Invoice/ Payment Invoice of the OEM (OR)
- III. Central Excise Gate Pass/Tax Invoice issued under relevant rules of Central Excise/Vat/GST.

2.3 The bidder shall confirm that the rotary table and its components will be tested, certified and monogrammed as per API 7K (latest edition).

2.4 The bidder quoted as manufacturer must submit an undertaking (in original on their official letter head) that, their API 7K certificate along with authorization for API monogram, will be kept valid till execution of the purchase order and must confirm that, the offered product will be supplied with API Monogram.

2.5 Bidder quoted as manufacturer must furnish a warranty back-up (in original on their official letter head) against the quality of the tendered item(s) as specified in the tender.

2.6 Bidder quoted as manufacturer must furnish a guarantee (in original on their official letter head) for uninterrupted supply of spares and availability of service for the item(s) to be supplied under the tender / order, for at least 10 (ten) years, with effect from delivery of the item(s), if order is awarded to them by OIL.

2.7 If the bidder is a manufacturer and has supplied the tendered item(s) to OIL in the last 10 (ten) years as on original bid closing date either by themselves or through their sole selling agent/ distributor/ dealer/ supply house) and whose past performance has been satisfactory, the bidder need not satisfy Clause 2.2. In this situation, the bidder shall have to indicate the Purchase Order number(s) of OIL executed successfully, in their technical bid.

3.0 IN CASE THE BIDDER IS NOT A MANUFACTURER:

If the bidder is a sole selling agent / distributor / dealer / supply house of any manufacturer of the offered item(s), then bidder must furnish the following documents along with the technical bid, failing which the bids will be rejected:

3.1.1 Authorization certificate from the manufacturer (in original on manufacturer's official letter head) should be submitted along with the technical bid. This certificate should be valid at the time of bidding and should remain valid during the entire execution period of the order.

3.1.2 Undertaking from the manufacturer (in original on manufacturer's official letter head) guaranteeing supply of item(s) to the bidder in the event of an order on the bidder. This certificate should be valid at the time of bidding and should remain valid during the entire execution period of the order.

3.1.3 Warranty backup from the manufacturer (in original on manufacturer's official letter head) against the quality of the tendered item(s) as specified in the tender.

3.1.4 Confirmation from the manufacturer (in original on manufacturer's official letter head) that the rotary table and its components will be tested, certified and monogrammed as per API 7K (latest edition).

3.1.5 Undertaking from the manufacturer (in original on manufacturer's official letter head) that their API 7K certificate along with authorization for API monogram will be kept valid till execution of purchase order and that the offered product will be supplied with API monogram.

3.1.6 Undertaking from the manufacturer (in original on manufacturer's official letter head), guaranteeing uninterrupted supply of spares and availability of service for the item(s) to be supplied under the tender/order, for at least 10 (ten) years with effect from delivery of the item(s), if order is awarded to them by OIL.

3.2.1 Copies of valid API Spec 7K certificates of the OEM of their quoted product, for the last 05 (five) year period, as specified under para 2.1.1 above.

3.2.2 Copy(s) of currently valid API Spec Q1 or ISO 9001 certificate of the OEM of their quoted product, in line with para 2.1.2 above.

3.3 Documentary evidence in respect of manufacturing and supply experience as specified under para 2.2 above, from the concerned manufacturer (having supplied

such items either by manufacturer themselves or through their sole selling agent / distributor / dealer / supply house) along with the techno-commercial bid.

3.4 Documentary evidence in respect of bidder's own supply experience of supplying at least 01 (one) number of Rotary Table of same or higher size and same or higher capacity, to any E&P companies/ Drilling Contractors / Drilling service providers during last 10 (years), as on original bid closing of the tender.

Documentary evidence in respect of supplying the above mentioned items should be submitted along with the technical bid, in the form of copies of relevant Purchase Orders and copies of any of the following documents, in respect of satisfactory execution of each of those Purchase Orders, failing which the bid will be rejected:

- I. Signed and sealed Satisfactory supply / completion / installation report (OR)
- II. Bill of Lading (OR)
- III. Consignee receipted delivery receipt/ challan (OR)
- IV. Central Excise Gate Pass/Tax Invoice issued under relevant rules of Central Excise/Vat. (OR)
- V. Commercial Invoice/ Payment Invoice

Note:

a) The Purchase Order date need not be within 10 (years) preceding original bid closing date of this tender. However, the execution of supply should be within 10 (years) preceding the original bid closing date of this tender.

b) Original Bid Closing Date shall be considered by OIL for evaluation of BRC Criteria in case of any extension of the bid closing date.

c) Satisfactory supply / completion/ installation report should be issued on Client's official letterhead with signature and stamp. Originals to be produced for verification on demand of OIL.

d) In case, for supplementing the supply experience criteria for both itself and the concerned manufacturer (3.4 & 3.3), the sole selling agent/ distributor/ dealer/ supply house of manufacturer submits same set of signed Purchase Order(s) and relevant documents, then following additional documents are also to be submitted:

Copies of signed Purchase Order(s)/ Contract agreement(s) between the manufacturer and the sole selling agent/ distributor/ dealer/ supply house and



copies of any of the following documents in respect of satisfactory execution of each of those Purchase Order(s)/Contract agreements(s).

- I. Bill of Lading (OR)
- II. Commercial Invoice/ Payment Invoice of the OEM (OR)
- III. Central Excise Gate Pass/Tax Invoice issued under relevant rules of Central Excise/Vat/GST.

3.5 If the bidder is a sole selling agent / distributor / dealer / supply house of any manufacturer and have successfully supplied the tendered items to OIL in the last 10 (ten) years, as on original bid closing date and whose past performance has been satisfactory, the bidder need not satisfy Clause 3.4 above. In this situation, the bidder shall have to indicate the Purchase Order number(s) of OIL executed successfully, in their technical bid.

However, this exemption shall be applicable only if the bidder has declared in their bid that, they will be supplying the tendered item(s) from the same manufacturer, as per the last order supplied to OIL.

#### 4.0 DELIVERY PERIOD:

INDIAN BIDDER: Materials must be despatched within (9) Nine months from the date of placement of order by OIL. The date of clear LR or C/Note shall be considered as the date of delivery.

FOREIGN BIDDER: Materials must delivered on FOB, Port of Shipment basis (9) Nine months from the date of opening of Letter of Credit by OIL. The date of unambiguous Bill of Lading (B/L) shall be considered as the date of delivery.

Bids submitted by Bidders quoting delivery period more than the above-mentioned duration shall not be accepted. Bidders must categorically confirm the delivery period in their Technical Bid.

#### **(A.2) BRC - FINANCIAL:**

- 1.0 The bidder shall have an annual financial turnover from Operations of minimum **INR 115.00 Lakhs or USD 146,800.00** during any of the preceding 3 (Three) financial/accounting years reckoned from the original bid closing date of the tender.

{Annual Financial Turnover of the bidder from operations shall mean - "Aggregate value of the realization of amount made from the sale, supply or

distribution of goods or on account of services rendered, or both, by the company (bidder) during a financial year" as per the Companies Act, 2013 Section 2 (91 ). }

- 2.0 "Net Worth" of the bidder must be positive for the financial/accounting year just preceding to the original Bid Closing Date of the Tender.

{ Net worth shall mean: "Share capital + Reserves created out of profits and securities Premium - Aggregate value of accumulated losses (excluding revaluation reserves) - deferred expenditure - Miscellaneous Expenditure to the extent not written off and carried forward Loss - Reserves created out of write back of depreciation and amalgamation".}

- 3.0 Considering the time required for preparation of Financial Statements, if the last date of preceding financial/accounting year falls within the preceding six months reckoned from the original bid closing date and the Financial Statements of the preceding financial/accounting year are not available with the bidder, then the financial turnover of the previous three financial/accounting years excluding the preceding financial/accounting year will be considered. In such cases, the Net worth of the previous financial/accounting year excluding the preceding financial/accounting year will be considered. However, the bidder has to submit an affidavit/undertaking (**PROFORMA - 8**) certifying that 'the balance sheet/Financial Statements for the financial year (as applicable) has actually not been audited so far'.

**Note:**

- a) For proof of Annual Turnover & Net worth any one of the following document must be submitted along with the technical bid:-
- i) A certificate issued by a practicing Chartered Cost Accountant (with Membership Number and Firm Registration Number), certifying the Annual Turnover & Net worth as per format prescribed in (**PROFORMA - 9**)

OR

  - ii) Audited Balance Sheet alongwith Profit & Loss account. In case of foreign bidders, self-attested/digitally signed printed published accounts are also acceptable.
- b) In case the bidder is a Central Govt. Organization/PSU/State Govt. Organization/Semi-State Govt. Organization or any other Central/ State Govt. Undertaking, where the auditor is appointed only after the approval of Comptroller and Auditor General of India and the Central Government, their certificates may be accepted even though FRN is not

available. However, bidder to provide documentary evidence for the same.

- 4.0 In case the Audited Balance Sheet and Profit & Loss Account submitted along with the bid are in currencies other than INR or US\$, the bidder shall have to convert the figures in equivalent INR or US\$ considering the prevailing conversion rate on the date on which the Audited Balance Sheet and Profit & Loss Account is signed. A CA certificate is to be submitted by the bidder regarding converted figures in equivalent INR or US\$.
- 5.0 In case the Bidder is subsidiary company (should be 100% owned subsidiary of the parent/ultimate parent/holding company) who does not meet financial criteria by itself and submits its bid based on the strength of parent/ultimate parent/holding company, then following documents need to be submitted:
  - (i) Turnover of the parent/ultimate parent/holding company should be in line with Para A.2 (1.0) above.
  - (ii) Net Worth of the parent/ultimate parent/holding company should be positive in line with Para A.2 (2.0) above
  - (iii) Corporate Guarantee (**PROFORMA - 10**) on parent/ultimate parent/holding company's company letter head signed by an authorized official undertaking that they would financially support their wholly owned subsidiary company for executing the project/job in case the same is awarded to them.
  - (iv) Documents to substantiate that the bidder is as 100% subsidiary of the parent/ultimate parent/holding company.

### **(A.3) BRC – COMMERCIAL:**

Commercial Bid Rejection Criteria will be as per Section D of General Terms & Conditions of Global Tender (MM/GLOBAL/E-01/2005) with following Special Bid Rejection Criteria.

- 1.0 Bids are invited online under **SINGLE STAGE TWO BID SYSTEM**. Bidders must prepare the Techno-Commercial Bid (Unpriced) as well as the Priced Bid separately and upload both these bids in OIL's e-procurement portal at the designated fields separately assigned. **Please note that no price details should be furnished in the Technical (i.e. Unpriced) bid.** The "Unpriced Bid" shall contain all techno-commercial details except the prices/costs. The rate and amount columns in the unpriced technical bid must be kept blank. The "Price Bid" must contain the price schedule and the bidder's commercial terms and conditions. Bidder not complying with above submission procedure will be rejected.
- 2.0 The prices/rates offered against the tender must remain firm through delivery and not subject to variation on any account. A bid submitted with an adjustable price condition shall be treated as non-responsive and

rejected. No discount whatsoever should be quoted separately. Rates/prices quoted must be net of all discount.

- 3.0 Bids received in physical form against online invitation shall be rejected (except the documents specifically called for in hard copies, if any). Also, modifications to bids received after the bid closing date & time shall not be entertained.
- 4.0 Bids containing incorrect/false/misleading statement(s) shall be rejected.
- 5.0 Validity of the bid shall be **minimum 120 days** from the date of actual Bid Closing Date. Bids with lesser validity shall be straightway rejected.
- 6.0 Successful bidder will be required to furnish a Performance Bank Guarantee @**3%** of the order value. The Performance Security specified above must be valid for 3(three) months beyond the Warranty period indicated in the Purchase Order/contract agreement [*Please refer "General Terms & Conditions" for e-Procurement as per Booklet No. MM/GLOBAL/E-01/2005 for E-procurement (ICB Tenders) including Amendments & Addendum to "General Terms & Conditions" for e-Procurement*]]. Bidder must confirm the same in their Technical Bid. Offers not complying with this clause will be rejected.
- 7.0 Additional Performance Security for PP-LC policy benefit: In Case the bidder seeks benefits as per PP-LC policy and the PO is awarded based on PP-LC policy benefit, then the bidder shall have to submit additional Bank Guarantee (format enclosed as PROFORMA-XIV) equivalent to 10 % of Total PO value towards fulfilment of conditions pertaining to Local Contents in accordance with the value mentioned in the certificate of LC.
- 8.0 Online Bid must be uploaded together with the Integrity Pact and the same must be duly signed digitally. If any bidder refuses to sign Integrity Pact or declined to submit Integrity Pact with the offer, their bid shall be rejected straightway.
- 9.0 Bidders are to quote for all the items in full quantity as indicated in the NIT.
- 10.0 Bidders shall accept and comply with the following clauses as given in the Bid Document, failing which bid shall be liable for rejection:
  - i) Liquidated Damages
  - ii) Warranty/Guarantee of material
  - iii) Arbitration / Resolution of Dispute
  - iv) Force Majeure
  - v) Applicable Laws

11.0 A bid shall be rejected straightway if it does not conform to any one of the following clauses:

- a) Validity of bid shorter than the validity indicated in the Tender.
- b) In case the party refuses to sign Integrity Pact.

## 12.0 PRICE SCHEDULE:

Bidder shall submit the Price Break up as per Price Bid Format (ANNEXURE - G). Bidders should fill up the annexure(s), sign and upload under "Notes & Attachments" > "Attachments" only.

### BB: BID EVALUATION CRITERIA:

1.0 Items will be evaluated separately. Bidders must submit prices as indicated in the Price Bid Format (Annexure G). In case, any charges (except basic material value) are not indicated item wise specifically, the charges quoted would be pro-rata calculated and the same will be binding on the bidder. Hence, bidders are requested to quote accordingly.

2.0 The bids conforming to the specifications, terms and conditions stipulated in the enquiry and considered to be responsive after subjecting to the Bid Rejection Criteria will be considered for further evaluation as per the Bid Evaluation Criteria given below:

#### (i) Price Bid Format (SUMMARY) for Foreign Bidders:

- (1) Basic Material Value excluding TPI, if any (to indicate HSN code):
- (2) Pre-despatch Inspection Charges, if any
- (3) Packing & FOB charges
- (4) FOB Value (1+2+3)
- (5) Ocean Freight Charges upto Kolkata, India
- (6) Insurance, @0.5% of Total FOB Value (4)
- (7) Banking Charges @1 % of Total FOB Value (4) above in case of payment through Letter of Credit. If confirmed L/C at buyer's account is required, 1.5% of Total FOB Value(4) will be loaded)
- (8) CIF Landed Value (4+5+6+7)
- (9) Basic Custom Duty (including cess, if any) on (8)
- (10) CIF Landed Value + CD (8+9)
- (11) IGST (including cess, if any) on (10)
- (12) Compensatory Cess on (11), if any:
- (13) CIF+CD+GST Landed Value, (10+11+12)
- (14) Training Charges, if any:
- (15) GST on Training Charges (14):
- (16) Installation & Commissioning Charges, if any:
- (17) GST on Installation & Commissioning Charges (16):
- (18) AMC Charges, if any
- (19) GST on AMC Charges (18)

**(20) Total Value (13+14+15+16+17+18+19)**

**(i) Price Bid Format (SUMMARY) for Indigenous Bidders:**

- (1) Basic Material Value excluding TPI, if any (to indicate HSN code)
- (2) Pre-despatch Inspection Charges, if any inclusive of GST
- (3) Packing & Forwarding charges, if any
- (4) Total Ex-Works Value (1+2+3)
- (5) GST on Ex-Works Value (4)
- (6) Compensatory Cess, if any
- (7) Total FOR Despatching Station Value (4+5+6)
- (8) Inland Freight Charges upto Duliajan, Assam
- (9) GST on Inland Freight (8)
- (10) Transit Insurance Charges, if any including GST
- (11) Training Charges, if any
- (12) GST on Training Charges (11)
- (13) Installation & Commissioning Charges, if any
- (14) GST on Installation & Commissioning Charges (13)
- (15) AMC Charges, if any
- (16) GST on AMC Charges (15)
- (17) Total (7+8+9+10+11+12+13+14+15+16)

3.0 To ascertain the inter-se-ranking, the comparison of the responsive bids will be made as under, subject to corrections/adjustments given herein.

**(I) When only foreign bidders are involved:**

Comparison will be done on Total value vide SI. no 20.

**(II) When both foreign & Domestic bidders are involved:**

Comparison will be done on total value vide SI no 20 of foreign bidder and total value vide SI. no 17(excluding SI no 8, 9, 10) of domestic bidder.

**(III) When only domestic bidders are involved:**

Comparison will be done on Total value vide SI no 17 of Domestic bidder.

Note:

(a) Domestic bidders must quote inland freight charges upto Duliajan. In case bidder fails to quote inland freight charges, highest freight quoted by domestic bidder (considering pro-rata distance) against this tender or OIL's estimated freight, whichever is higher, shall be loaded to their offer for comparison purpose.

(b) For enquiries with duty exemption benefit - The items covered under this enquiry shall be used by OIL in the PEL/ML areas issued/renewed after 01/04/99 and hence, applicable Customs Duty for import of goods shall be ZERO. However, IGST@ 12 %shall be applicable. IGST@ 5% shall be applicable for Indigenous bidders also under deemed export benefit.

**4.0 Purchase Preferences (As quoted by bidder):**

- a) As per Gazette notification no. CG-DL-E-26062020-220191 dated 26.06.2020 issued by Ministry of Micro, Small and Medium Enterprises, MSE bidders whose quote price is within price band of L1+15%, such MSE shall be considered for award of contract by bringing down their price to L1 price in a situation where L1 price is from someone other than a MSE. In case of more than one such MSE qualifying for 15% purchase preference, the order shall be awarded to lowest eligible MSE amongst the MSEs qualifying for 15% purchase preference.

**Or**

- b) As per Purchase Preference Policy (linked with local content) as issued by Ministry of Petroleum & Natural Gas, Government of India vide notification no. FP-20013/2/2017-FP-PNG dated 17.11.2020, Class-I local bidder with local content equal to or more than 50% (or as amended by competent authority from time to time) shall be eligible for purchase preference of 20%. Offer evaluation and award of order shall be based on the provisions of aforesaid policy.

5.0 If there is any discrepancy between the unit price and the total price, the unit price will prevail and the total price shall be corrected. Similarly, if there is any discrepancy between words and figure, the amounts in words shall prevail and will be adopted for evaluation.

6.0 For conversion of foreign currency into Indian currency, B.C. selling (Market) rate declared by State Bank of India, one day prior to the date of price bid opening shall be considered. However, if the time lag between the opening of the bids and final decision exceed 3(three) months, then B.C. Selling(Market) rate of exchange declared by SBI on the date prior to the date of final decision shall be adopted for conversion and evaluation.

\*\*\*\*\*

**ANNEXURE - D**  
**TECHNICAL CHECKLIST**

Sl. No	DESCRIPTIONS	REMARKS
1	Whether quoted the item as manufacturer?	YES / NO
2	Whether quoted the item as sole selling agent / distributor / dealer / supply house of any manufacturer?	YES / NO
3	Whether the items would be brand new, unused & of prime quality ?	YES / NO
4	Whether the offered Rotary Table is 650 Tons (590 tonnes) static load capacity?	YES / NO
5	Whether the Rotary Table opening is 37.1/2" (953 mm)?	YES / NO
6	Whether the item would be manufactured as per API spec. 7K (latest edition) and SR-3?	YES / NO
7	Whether copies of API spec. 7K certificate of the manufacturer for the last 5 (five) year period preceding original bid closing date has been forwarded along with the quotation?	YES / NO
8	Whether detailed technical catalogues, literature and drawings indicating exploded view and dimensions with part numbers for the offered items are forwarded?	YES / NO
9	Whether the item would be free from all defects & fault in material, workmanship & manufacture and shall be in full conformity with ordered specifications?	YES / NO
10	Whether warranty would be for 18 months from date of shipment or 12 months from date of commissioning of the items whichever is earlier?	YES / NO
11	Whether the defective item/ parts, if any, rejected by us will be replaced by you free of cost?	YES / NO
12	Whether list of recommended spare parts for 02 (two) years' trouble free operation with unit price and part numbers of each and every item (year wise) along with the quotation are forwarded?	YES / NO
13	Whether mention the name of manufacturer, country of origin and place of dispatch?	YES / NO
14	Whether purchase order number and manufacturer's names would be stamped on the items?	YES / NO
15	Whether the manufacturing data/record book pertaining to the item would be provided along with the supply as per API Spec 7K (latest edition), SR-3?	YES / NO
16	Whether you (other than OEM) have forwarded the copy of authorization letter from the original equipment manufacturer?	YES / NO
17	Any deviation from NIT?	YES / NO



**COMMERCIAL CHECK LIST**

- A. The Commercial Check List must be completed and returned with your offer. Please ensure that all these points are covered in your offer. These will ensure that your offer is properly evaluated. Please select "yes" or "no" to the following questions, in the right hand column.

Sl. No.	REQUIREMENT	COMPLIANCE Yes/No/ Not Applicable
1.0	Whether bid submitted under Single Stage Two Bid System?	
2.0	Whether quoted as manufacturer?	
2.1	Whether quoted as OEM Dealer/Supply House.	
2.2	If quoted as OEM Dealer/Supply House	
	(a) Whether submitted valid and proper authorization letter from manufacturer confirming that bidder is their authorized Dealer/supply House for the product offered ?	
	(b) Whether manufacturer's back-up Warranty/Guarantee certificate submitted?	
3.0	Whether Purchase Preference claimed? If so, whether under -	
	(i) PPLC (Whether relevant documents uploaded?)	
	(ii) MSE (Whether relevant documents uploaded?)	
	(iii) DMS&IP (Whether relevant documents uploaded?)	
4.0	Whether offered firm prices?	
4.1	Whether quoted offer <b>validity of 120 days from</b> the bid closing date of tender?	
4.2	Whether quoted a firm delivery period?	
4.3	Whether agreed to the NIT Warranty clause?	
4.4	Whether confirmed acceptance of tender Payment Terms as per Tender?	
5.0	Whether confirmed to submit PBG as asked for in NIT?	
5.1	Whether agreed to submit PBG within 30 days of placement of order?	
6.0	Whether Price submitted as per Price Schedule?	
6.1	Whether cost of Recommended Spares for 2 years of operations quoted (if applicable)?	
7.0	Whether quoted as per NIT (without any deviations)?	
7.0	Whether quoted any deviation?	
7.1	Whether deviation separately highlighted?	
8.0	Whether indicated the country of origin for the items quoted?	
8.1	Whether technical literature / catalogue enclosed?	
8.2	Whether weight & volume of items offered indicated?	
9.0	For Foreign Bidders - Whether offered FOB/FCA port of	

	despatch including sea/air worthy packing & forwarding?	
9.1	For Foreign Bidders – Whether port of shipment indicated? To specify:	
9.2	For Foreign Bidders only - Whether indicated ocean freight up to Kolkata port (Excluding marine insurance)?	
9.3	Whether Indian Agent applicable?	
	If YES, whether following details of Indian Agent provided?	
	(a) Name & address of the agent in India – To indicate	
	(b) Amount of agency commission – To indicate	
	(c) Whether agency commission included in quoted material value?	
10.0	For Indian Bidders – Whether indicated the place from where the goods will be dispatched. To specify :	
10.1	For Indian Bidders – Whether road transportation charges up to Dulliajan quoted?	
10.2	For Indian Bidders only - Whether offered Ex-works price is including packing/forwarding charges?	
10.3	For Indian Bidders only - Whether indicated import content in the offer?	
10.4	For Indian Bidders only - Whether offered Deemed Export prices?	
10.5	For Indian Bidders only – Whether all applicable Taxes & Duties have been quoted?	
11.0	Whether all BRC/BEC clauses accepted?	
12.0	Whether Integrity Pact with digital signature uploaded?	
12.1	Whether all the clauses in the Integrity Pact have been accepted?	
13.0	<b>Whether indicated 'Local Content' required as per PPLC Policy?</b>	
14.0	<b>Whether indicated the import content in Price Bid?</b>	

**B. ADDITIONAL INFORMATION (To be filled up by bidder and submit along with Technical Bid):**

<b>SI N o</b>	<b>Requirement</b>	<b>Bidder's Reply</b>
1	Offer reference & Date	
2	Name, Address, Phone No & E-mail of Bidder	
3	Bank details of Bidder	
4	Name of Manufacturer	
5	Bid validity	
6	Payment Terms	
7	Guarantee/Warranty Terms	
8	Delivery Period	
9	Country of Origin	
10	Port of Despatch/Despatching Station	
11	Confirm submission Integrity pact, if required as per NIT	
12	Confirm acceptance of PBG clause, if required as per NIT	
13	Compliance to: Liquidated Damage Warranty/Guarantee Arbitration/Resolution of Dispute Force Majeure Applicable laws	
14	Confirm submission of the balance sheet/Financial Statements for the financial year (as applicable). If not, whether declaration as per BRC submitted <b>(PROFORMA - 8)</b> .	
15	Confirm submission of undertaking towards authenticity of submitted documents.	
16	Exception/Deviations quoted, if any, to be given in details or refer to respective page of the bid documents. ANNEXURE III of General Terms & Conditions" for e-Procurement as per Booklet No. MM/GLOBAL/E-01/2005 for E-procurement (ICB Tenders) submitted in this regard?	
17	Whether submitted all the applicable Annexures as per document General Terms & Conditions" for e-Procurement as per Booklet No. MM/GLOBAL/E-01/2005 for E-procurement (ICB Tenders).	

**C. ADDITIONAL INFORMATION ON EXPERIENCE CRITERIA CLAUSE OF BRC-TECHNICAL. (To be filled up by bidder and submit along with Technical Bid):**

S I N O	Requirement	Bidder's Reply
1	Whether all documents have been submitted as required for fulfilling Experience criteria clause of BRC-Technical.	
2	Name and details of the <b>E&amp;P company / Drilling Contractor / Drilling Service</b> provider to whom the bidder has successfully executed orders / contracts for atleast 50% of the tendered quantity as per Experience criteria clause of BRC-Technical.	
3	Whether submitted the profile and other documents of the E&P company / Drilling Contractor / Drilling Service provider for verification (viz. Annual reports, Memorandum of Association, Article of Association etc.)	

\*\*\*\*\*

**ANNEXURE - E**

<b>BID EVALUATION MATRIX (TECHNICAL) (TO BE FILLED IN BY BIDDER DULY SIGNED)</b>
<b>As per Annexure - B TECHNICAL SPECIFICATIONS</b>

\*\*\*\*\*

**ANNEXURE - F**

<b>BID EVALUATION MATRIX (BID REJECTION CRITERIA) (TO BE FILLED IN BY BIDDER DULY SIGNED)</b>		
<b>BID EVALUATION CRITERIA</b>		
<b>DESCRIPTION</b>	<b>BIDDER'S RESPONSE (Complied / Not Complied /Deviation/Not Applicable )</b>	<b>TO BE FILLED BY THE BIDDER</b>  <b>Relevant Location of their Bid to support the remarks / compliance</b>  <b>(Reference of Document name / Serial number / Page number of bid for documentary evidence)</b>
<b>(A.1) <u>BRC-TECHNICAL:</u></b>  1.0 The Rotary Table shall be designed, manufactured, tested, monogrammed and certified as per API Spec. 7K (latest edition), SR-3.  2.1.1.A The bidder should have an experience of minimum 05 (five) years in manufacturing the tendered		

item conforming to API Spec. 7K certification on continuous basis. For this purpose, the period reckoned shall be prior to the date of original bid closing date of the tender.

Copies of API Spec. 7K certificates, having authorization for manufacturing of Rotary Table, for the last 05 (five) years (on continuous basis without having any breaks in between), must be submitted along with the techno-commercial bid. Bid without copies of valid API Spec. 7K certificates or without the required API authorization for manufacturing of Rotary Table or with a break in the continuity of the API certification, will be rejected.

2.1.1.B For Indian Bidders who is manufacturer of the tendered items (OEM of the Tendered Items), with valid API 7K certificate having authorisation for manufacturing Rotary Table covering a period of at least 10 years in last 15 years preceding the original bid closing date of this tender must be submitted along with the techno commercial bid.

All other terms of this tender remain same for both Indian and Foreign bidder.

Note:

a) In case, renewal process of the API 7K certificate of the manufacturer is in progress at the time of bidding, then the manufacturer should furnish a letter from API to this effect that, their certification is under examination for renewal with API and is authorized to manufacture and monogram the items as per API Spec. 7K, till the renewed license is issued.

b) The bidder shall also submit an undertaking that, any delay in renewal of their API 7K certificate, shall not affect the stipulated delivery schedule of the tender / purchase order.

2.1.2 Additionally, the bidder should also have API Spec. Q1 or ISO 9001 certification for manufacturing of Rotary Tables. Copy(s) of API Spec Q1 or ISO 9001 certificate, valid as on original bid closing date of the tender, should be submitted along with the bid, without which their bid will be rejected.

2.2 The bidder should have manufactured and supplied minimum 01 (one) number of Rotary Table of same or higher size and same or higher capacity, to E&P Companies/ Drilling Contractors/ Drilling Service Providers during the last 10 (years) as on original bid closing date of the tender (either by themselves or through their sole selling agent/ distributor/ dealer/ supply house).

Documentary evidence in respect of manufacturing and supplying the above mentioned item(s), should be submitted along with the technical bid, in the form of copies of relevant Purchase Orders and copies of any of the following documents, in respect of satisfactory execution of each of those Purchase Orders, failing which the bid will be rejected:

- I. Signed and sealed Satisfactory supply / completion / installation report (OR)
- II. Bill of Lading (OR)
- III. Consignee receipted delivery receipt/ challan (OR)
- IV. Central Excise Gate Pass/Tax Invoice issued under relevant rules of Central Excise/Vat. (OR)
- V. Commercial Invoice/ Payment Invoice

Note:

a) The Purchase Order date(s) need not be within 10 (years) preceding original bid closing date of this tender. However, the execution of supply should be within 10 (years) preceding the original bid closing date of this tender.

b) Original Bid Closing Date shall be considered by OIL for evaluation of BRC Criteria in case of any extension of the bid closing date.

c) Satisfactory supply/ completion/ installation report should be issued on Client's official letterhead with signature and stamp. Originals to be produced for verification on demand of OIL.

d) In case, for supplementing the manufacturer's supply

experience criteria, the manufacturer submits Purchase Order(s) and relevant documents which are through their sole selling agent/ distributor/ dealer/ supply house, then following additional documents are also to be submitted:

Copies of signed Purchase Order(s)/ Contract agreement(s) between the manufacturer and the sole selling agent/ distributor/ dealer/ supply house and copies of any of the following documents in respect of satisfactory execution of each of those Purchase Order(s)/ Contract agreements(s):

- I. Bill of Lading (OR)
- II. Commercial Invoice/ Payment Invoice of the OEM (OR)
- III. Central Excise Gate Pass/Tax Invoice issued under relevant rules of Central Excise/Vat/GST.

2.3 The bidder shall confirm that the rotary table and its components will be tested, certified and monogrammed as per API 7K (latest edition).

2.4 The bidder quoted as manufacturer must submit an undertaking (in original on their official letter head) that, their API 7K certificate along with authorization for API monogram, will be kept valid till execution of the purchase order and must confirm that, the offered product will be supplied with API Monogram.

2.5 Bidder quoted as manufacturer must furnish a warranty back-up (in original on their official letter head) against the quality of the tendered item(s) as specified in the tender.

2.6 Bidder quoted as manufacturer must furnish a guarantee (in original on their official letter head) for uninterrupted supply of spares and availability of service for the item(s) to be supplied under the tender / order, for at least 10 (ten) years, with effect from delivery of the item(s), if order is awarded to them by OIL.

2.7 If the bidder is a manufacturer and has supplied the tendered item(s) to OIL in the last 10 (ten) years as on original bid closing date either by themselves or through



their sole selling agent/ distributor/ dealer/ supply house) and whose past performance has been satisfactory, the bidder need not satisfy Clause 2.2. In this situation, the bidder shall have to indicate the Purchase Order number(s) of OIL executed successfully, in their technical bid.

### 3.0 IN CASE THE BIDDER IS NOT A MANUFACTURER:

If the bidder is a sole selling agent / distributor / dealer / supply house of any manufacturer of the offered item(s), then bidder must furnish the following documents along with the technical bid, failing which the bids will be rejected:

3.1.1 Authorization certificate from the manufacturer (in original on manufacturer's official letter head) should be submitted along with the technical bid. This certificate should be valid at the time of bidding and should remain valid during the entire execution period of the order.

3.1.2 Undertaking from the manufacturer (in original on manufacturer's official letter head) guaranteeing supply of item(s) to the bidder in the event of an order on the bidder. This certificate should be valid at the time of bidding and should remain valid during the entire execution period of the order.

3.1.3 Warranty backup from the manufacturer (in original on manufacturer's official letter head) against the quality of the tendered item(s) as specified in the tender.

3.1.4 Confirmation from the manufacturer (in original on manufacturer's official letter head) that the rotary table and its components will be tested, certified and monogrammed as per API 7K (latest edition).

3.1.5 Undertaking from the manufacturer (in original on manufacturer's official letter head) that their API 7K certificate along with authorization for API monogram will be kept valid till execution of purchase order and that the offered product will be supplied with API monogram.

3.1.6 Undertaking from the manufacturer (in original on

<p>manufacturer's official letter head), guaranteeing uninterrupted supply of spares and availability of service for the item(s) to be supplied under the tender/order, for at least 10 (ten) years with effect from delivery of the item(s), if order is awarded to them by OIL.</p> <p>3.2.1 Copies of valid API Spec 7K certificates of the OEM of their quoted product, for the last 05 (five) year period, as specified under para 2.1.1 above.</p> <p>3.2.2 Copy(s) of currently valid API Spec Q1 or ISO 9001 certificate of the OEM of their quoted product, in line with para 2.1.2 above.</p> <p>3.3 Documentary evidence in respect of manufacturing and supply experience as specified under para 2.2 above, from the concerned manufacturer (having supplied such items either by manufacturer themselves or through their sole selling agent / distributor / dealer / supply house) along with the techno-commercial bid.</p> <p>3.4 Documentary evidence in respect of bidder's own supply experience of supplying at least 01 (one) number of Rotary Table of same or higher size and same or higher capacity, to any E&amp;P companies/ Drilling Contractors / Drilling service providers during last 10 (years), as on original bid closing of the tender.</p> <p>Documentary evidence in respect of supplying the above mentioned items should be submitted along with the technical bid, in the form of copies of relevant Purchase Orders and copies of any of the following documents, in respect of satisfactory execution of each of those Purchase Orders, failing which the bid will be rejected:</p> <p>I. Signed and sealed Satisfactory supply / completion / installation report (OR)  II. Bill of Lading (OR)  III. Consignee receipted delivery receipt/ challan (OR)  IV. Central Excise Gate Pass/Tax Invoice issued under relevant rules of Central Excise/Vat. (OR)  V. Commercial Invoice/ Payment Invoice</p>		
---	--	--

<p>Note:</p> <p>a) The Purchase Order date need not be within 10 (years) preceding original bid closing date of this tender. However, the execution of supply should be within 10 (years) preceding the original bid closing date of this tender.</p> <p>b) Original Bid Closing Date shall be considered by OIL for evaluation of BRC Criteria in case of any extension of the bid closing date.</p> <p>c) Satisfactory supply / completion/ installation report should be issued on Client's official letterhead with signature and stamp. Originals to be produced for verification on demand of OIL.</p> <p>d) In case, for supplementing the supply experience criteria for both itself and the concerned manufacturer (3.4 &amp; 3.3), the sole selling agent/ distributor/ dealer/ supply house of manufacturer submits same set of signed Purchase Order(s) and relevant documents, then following additional documents are also to be submitted:</p> <p>Copies of signed Purchase Order(s)/ Contract agreement(s) between the manufacturer and the sole selling agent/ distributor/ dealer/ supply house and copies of any of the following documents in respect of satisfactory execution of each of those Purchase Order(s)/Contract agreements(s).</p> <p>I. Bill of Lading (OR) II. Commercial Invoice/ Payment Invoice of the OEM (OR) III. Central Excise Gate Pass/Tax Invoice issued under relevant rules of Central Excise/Vat/GST.</p> <p>3.5 If the bidder is a sole selling agent / distributor / dealer / supply house of any manufacturer and have successfully supplied the tendered items to OIL in the last 10 (ten) years, as on original bid closing date and whose past performance has been satisfactory, the bidder need not satisfy Clause 3.4 above. In this situation, the bidder shall have to indicate the Purchase Order number(s) of OIL executed successfully, in their technical bid.</p>		
---	--	--

However, this exemption shall be applicable only if the bidder has declared in their bid that, they will be supplying the tendered item(s) from the same manufacturer, as per the last order supplied to OIL.

#### 4.0 DELIVERY PERIOD:

INDIAN BIDDER: Materials must be despatched within (9) Nine months from the date of placement of order by OIL. The date of clear LR or C/Note shall be considered as the date of delivery.

FOREIGN BIDDER: Materials must delivered on FOB, Port of Shipment basis (9) Nine months from the date of opening of Letter of Credit by OIL. The date of unambiguous Bill of Lading (B/L) shall be considered as the date of delivery.

Bids submitted by Bidders quoting delivery period more than the above-mentioned duration shall not be accepted. Bidders must categorically confirm the delivery period in their Technical Bid.

\*\*\*\*\*

**ANNEXURE - G(i)**  
**&**  
**ANNEXURE G(ii)**

**PRICE BID FORMAT**

**(Uploaded as attachment in the Attachment Tab "Notes and Attachments"  
in e-portal)**

ANNEXURE – H

Drawing etc.

# 37.1/2" ROTARY TABLE PAD EYE POSITIONS page1

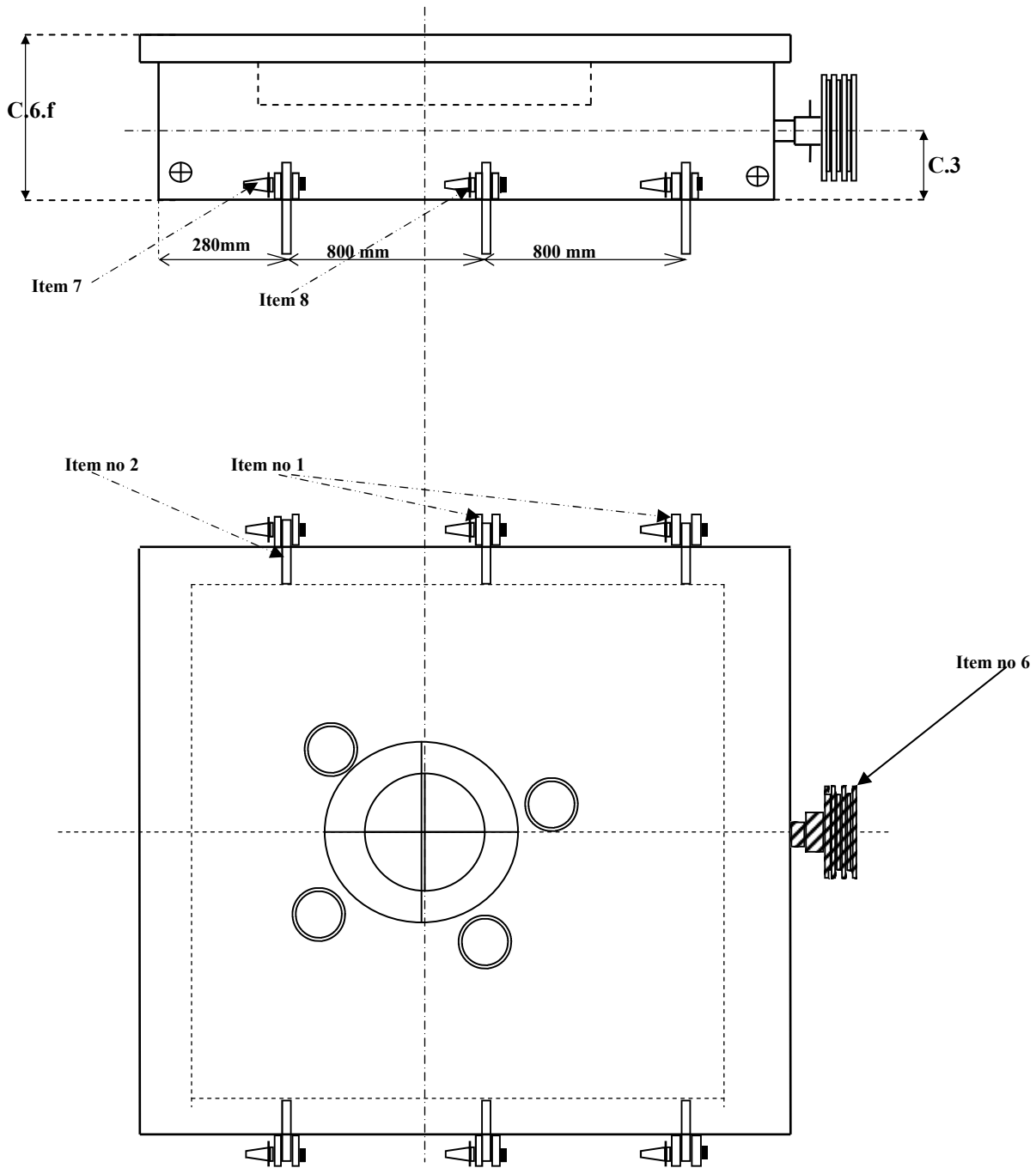

ITEM	DESCRIPTION	QUANTITY
1	Pad Eye Pair	12 Nos (six pair)
2	Pad Eye (With rig structure)	6 (Not to procure)
3	Bolt 3/4-10 UNC 2A	1
4	Pressure Pad	1
5	Key	1
6	Chain wheel / Sprocket	1
7	Pin shaft $\phi$ 50mm x 185mm	6
8	Pin $\phi$ 6mm x 185mm	6

# 37.1/2" ROTARY TABLE PAD EYE POSITIONS page 2

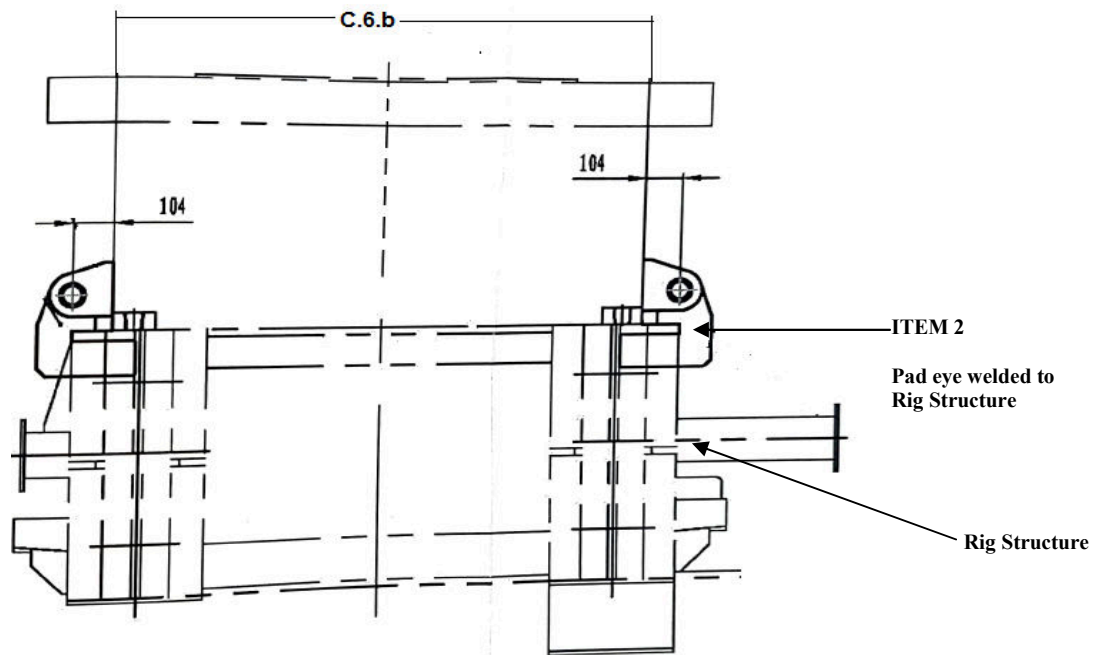
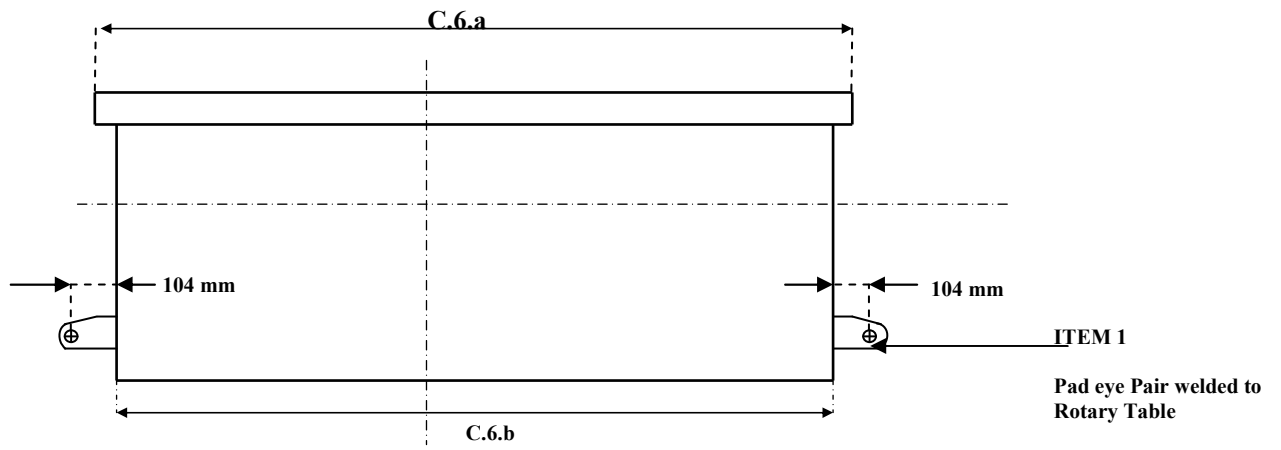



**37.1/2" ROTARY TABLE PAD EYE POSITIONS page 3**

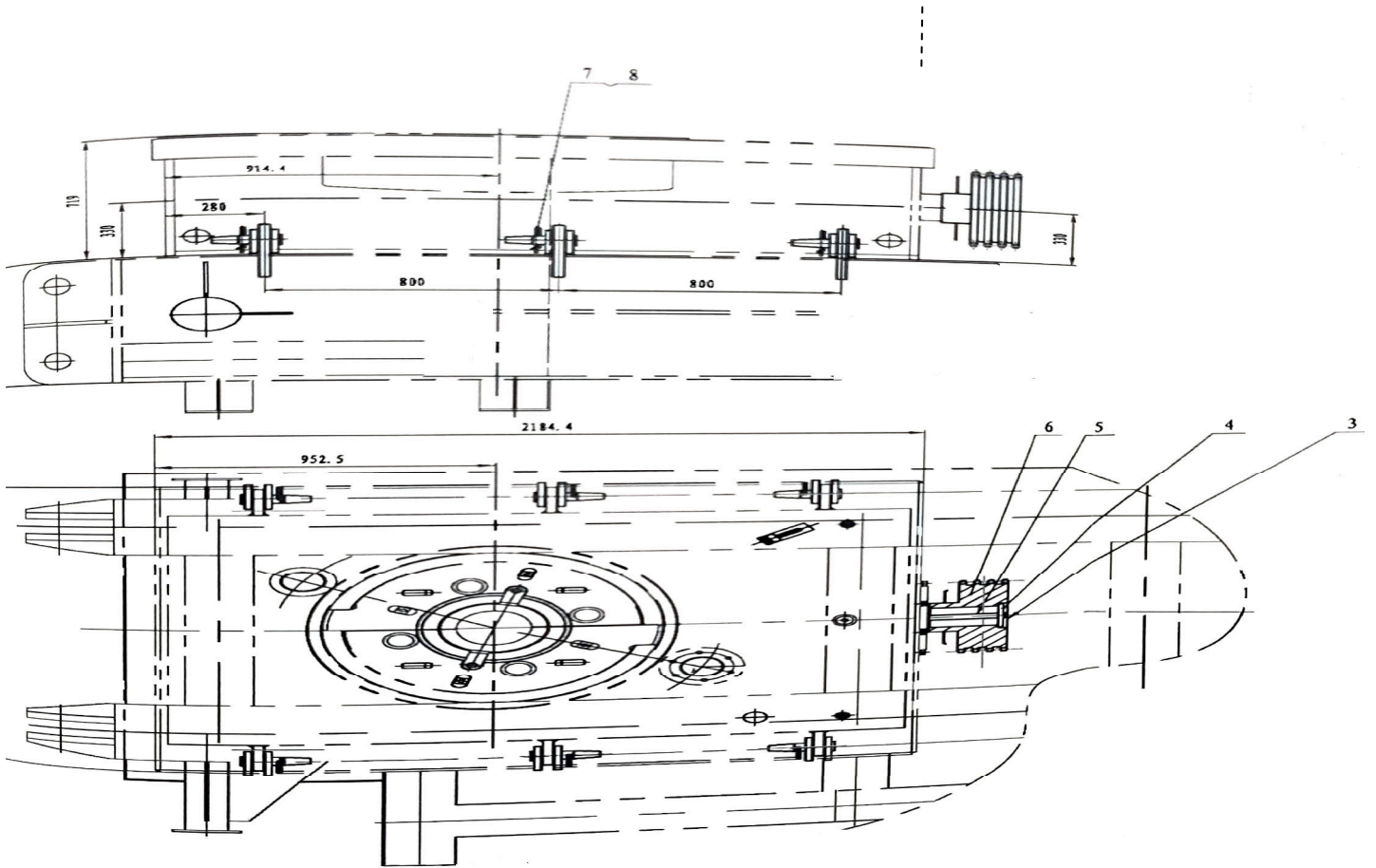

**The above figure is only for demonstration and not to scale**

# 37.1/2" ROTARY TABLE

